



## ARRL Periodicals Archive – Search Results

### A membership benefit of ARRL and the ARRL Technical Information Service

**ARRL Members:** You may print a copy for personal use. Any other use of the information requires permission (see Copyright/Reprint Notice below).

**Need a higher quality reprint or scan?** Some of the scans contained within the periodical archive were produced with older imaging technology. If you require a higher quality reprint or scan, please contact the ARRL Technical Information Service for assistance. Photocopies are \$3 for ARRL members, \$5 for nonmembers. For members, TIS can send the photocopies immediately and include an invoice. Nonmembers must prepay. Details are available at [www.arrl.org/tis](http://www.arrl.org/tis) or email [photocopy@arrl.org](mailto:photocopy@arrl.org).

**QST on CD-ROM:** Annual CD-ROMs are available for recent publication years. For details and ordering information, visit [www.arrl.org/qst](http://www.arrl.org/qst).

**Non-Members:** Get access to the ARRL Periodicals Archive when you join ARRL today at [www.arrl.org/join](http://www.arrl.org/join). For a complete list of membership benefits, visit [www.arrl.org/benefits](http://www.arrl.org/benefits).

### Copyright/Reprint Notice

In general, all ARRL content is copyrighted. ARRL articles, pages, or documents--printed and online--are not in the public domain. Therefore, they may not be freely distributed or copied. Additionally, no part of this document may be copied, sold to third parties, or otherwise commercially exploited without the explicit prior written consent of ARRL. You cannot post this document to a Web site or otherwise distribute it to others through any electronic medium.

For permission to quote or reprint material from ARRL, send a request including the issue date, a description of the material requested, and a description of where you intend to use the reprinted material to the ARRL Editorial & Production Department: [permission@arrl.org](mailto:permission@arrl.org).

**QST Issue:** Jun 2002

**Title:** Lightning Protection for the Amateur Station, Part 1

**Author:** W. Ronald Block, KB2UYT

[Click Here to Report a Problem with this File](#)



## 2010 ARRL Periodicals on CD-ROM

ARRL's popular journals are available on a compact, fully-searchable CD-ROM. Every word and photo published throughout 2010 is included!

- **QST** The official membership journal of ARRL
- **NCJ** National Contest Journal
- **QEX** Forum for Communications Experimenters

**SEARCH** the full text of every article by entering titles, call signs, names—almost any word. **SEE** every word, photo (including color images), drawing and table in technical and general-interest features, columns and product reviews, plus all advertisements. **PRINT** what you see, or copy it into other applications.

**System Requirements:** Microsoft Windows™ and Macintosh systems, using the industry standard Adobe® Acrobat® Reader® software. The Acrobat Reader is a free download at [www.adobe.com](http://www.adobe.com).

### 2010 ARRL Periodicals on CD-ROM

ARRL Order No. 2001

**Only \$24.95\***

\*plus shipping and handling

Additional sets available:

2009 Ed., ARRL Order No. 1486, \$24.95  
 2008 Ed., ARRL Order No. 9406, \$24.95  
 2007 Ed., ARRL Order No. 1204, \$19.95  
 2006 Ed., ARRL Order No. 9841, \$19.95  
 2005 Ed., ARRL Order No. 9574, \$19.95  
 2004 Ed., ARRL Order No. 9396, \$19.95  
 2003 Ed., ARRL Order No. 9124, \$19.95  
 2002 Ed., ARRL Order No. 8802, \$19.95  
 2001 Ed., ARRL Order No. 8632, \$19.95



**ARRL** The national association for AMATEUR RADIO™

SHOP DIRECT or call for a dealer near you.  
 ONLINE [WWW.ARRL.ORG/SHOP](http://WWW.ARRL.ORG/SHOP)  
 ORDER TOLL-FREE 888/277-5289 (US)

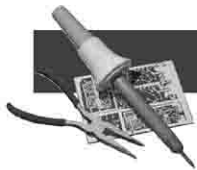

By Ron Block, KB2UYT

# Lightning Protection for the Amateur Station

*Part 1*—Lightning protection can be a serious issue for amateurs. In the first of this three-part series, the author leads us through the process of developing a protection plan. Next: how to protect your equipment. The final part will cover the process of creating an effective ground system.

## The Challenge

The amateur is challenged to assemble the best radio station possible, enjoy the benefits of the hobby, and have the station operable during times of need. This can be a significant challenge especially considering the awesome capabilities of Mother Nature's lightning strikes. While she may have the upper hand as far as when and how much energy she delivers, you have the ability to influence how that energy is diverted into the earth. Said another way, you can implement a lightning protection plan that will protect your Amateur Radio station, even from a direct strike!

The commercial radio folks have done this for years; many of them have critical installations located on hills or mountaintops that are great lightning strike targets. They do survive direct strikes and continue to provide important services to the communities that they serve. While this type of solution is possible for the Amateur Radio station, it does cost money and it does take a significant amount of resourcefulness, ingenuity, and effort to implement and maintain.

The plan does work; *but* you must follow all of the rules—exactly. Any violation of the rules, even just a little one, may result in a violation of the protection plan and damage to your equipment. In some cases the damage to a semi-protected radio station could be worse than if no protection plan had been implemented at all. I'll start with some background.

## Lightning Characteristics

The conditions necessary for an old-fashioned summer afternoon thunderstorm are lots of moist air from ground level to a few thousand feet, cooler air above with little to no wind, and plenty of sun to heat the air mass near the ground. As the warm, moist air is heated, it rises quickly to heights where the temperature is below freezing, eventually forming a thundercloud as shown in Figure 1. Within the thundercloud, the constant collisions among ice particles driven by the rising air causes a static charge to build up. Eventually the static charge becomes sufficiently large to cause the electrical breakdown of the air—a lightning strike.

The average thunderstorm is approximately six miles wide and travels at approximately 25 mph. The anvil shape of the cloud is due to a combination of thermal layer (tropopause) and upper high velocity winds that cause the top of the cloud



NOAA LIBRARY

Figure 1—A typical convective thunderhead.

to mushroom and be pushed forward. The area of imminent danger is the area up to 10 miles in front of the leading edge of the cloud.

When a lightning strike does occur, the return stroke rapidly deposits several large pulses of energy along the leader channel. That channel is heated by the energy to above 50,000°F in only a microsecond and hence has no time to expand while it is being heated, creating extremely high pressure. The high pressure channel rapidly expands into the surrounding air and compresses it. This disturbance of the air propagates outward in all directions. For the first 10 yards or so it propagates as a shock wave (faster than the speed of sound) and after that as an ordinary sound wave—the thunder we hear.

During a lightning strike your equipment is subjected to several huge impulses of energy. The majority of the energy is pulsed dc with a substantial amount of RF energy created by the fast rise time of the pulses. A typical lightning strike rise time is 1.8  $\mu$ S. That translates into a radiated RF signal at 139 kHz. Rise times can vary from a very fast 0.25  $\mu$ S to a very slow 12  $\mu$ S, yielding an RF range from 1 MHz down to 20 kHz. However, the attachment point for a direct lightning strike has a time as fast as 10 nS. This RF content of the strike

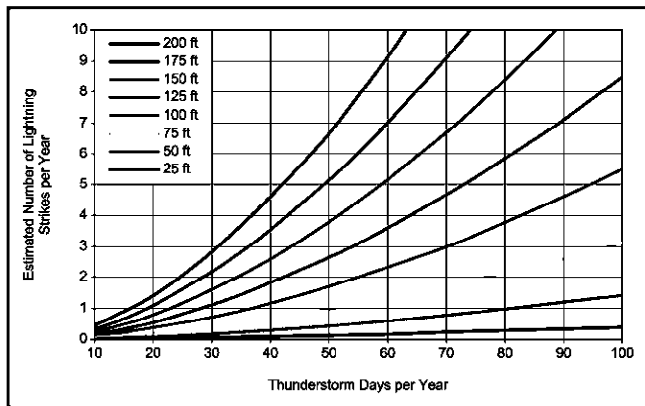
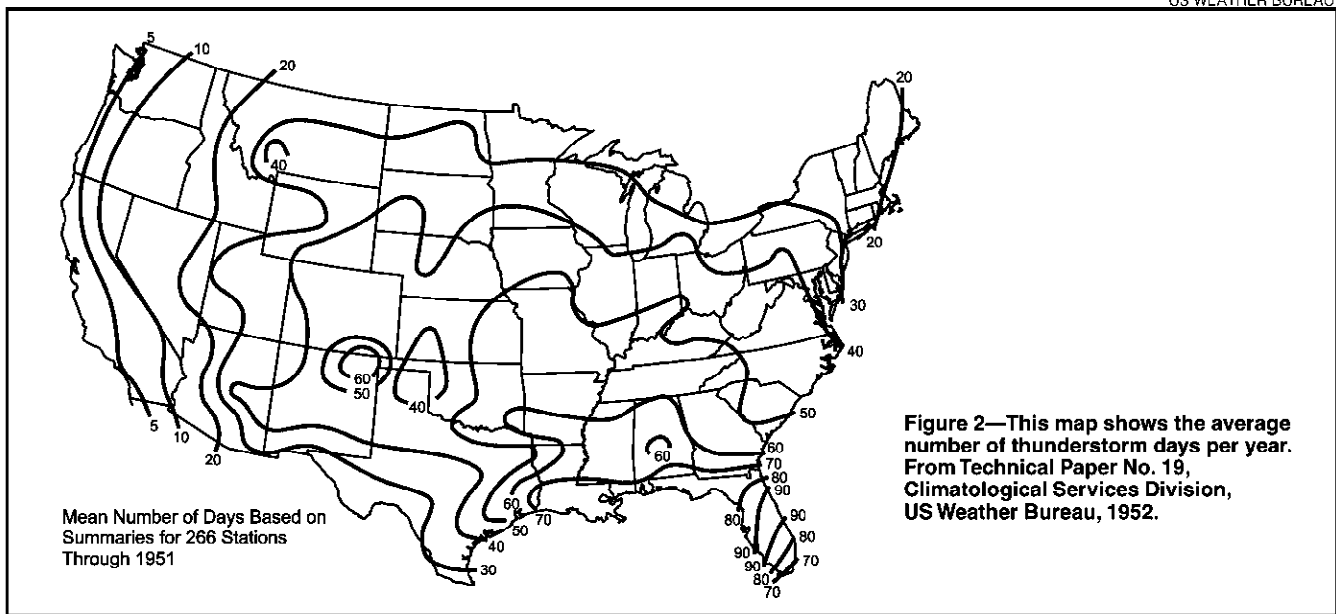

**Figure 3—Estimated number of lightning strikes per year based on the number of thunderstorm days in your area and the height of your antenna. Based on information from *Living with Lightning*, Seminar Notes #ECP-826B Version F, GE Mobile Radio Technical Training, © GE 1985.**

The probability of having your tower struck by lightning is governed primarily by where you are located and the height of the tower. In 1952, The Weather Bureau compiled a contour map of the US showing the mean number of thunderstorm-days that occur in a year shown in Figure 2. The counting criterion is relatively simple—a thunderstorm-day is one in which one or more claps of thunder are heard. This gives us a reasonable view of the country with respect to our exposure to lightning.

The other significant factor that affects the probability of being struck is the height of the tower above the average ground level. As you might suspect, the higher your tower, the higher the probability of being struck. Figure 3 shows the estimated number of times per year that a tower of a given height would be struck based on the number of thunderstorm-days in your area.

Now that you can estimate your approximate exposure, you might have one of several reactions. First, you could say the predictions are all wrong—personally, I have never had my 100-foot tower struck since I put it up two years ago. Maybe you are just lucky or the law of averages has yet to catch up with you. Another reaction you could have is, “Wow! This explains what has been happening and I had better do something about this right away.”

In either case, this article shows what you need to do to protect both your life and equipment, broken into straightforward steps to maximize your probability of success. Every Amateur Radio station is different and there is no “one size fits all” solution. There are, however, some well grounded (pun intended) principles that must be followed. A failure to follow the principles will result in the expenditure of both time and money with no better protection (possibly even worse damage) than if you had done nothing at all. Please follow each step carefully, thinking about the principles involved, and carefully apply the information to your specific installation.

### Identify What is to be Protected

The goal of the planning process is to establish a “zone of protection” within the radio room, as opposed to the whole house or building. Additional zones may be considered separately. The first step in the process is to identify what you want to protect. The immediate answer is, well, everything. While you can come close, you may run out of money, time, or energy. So let’s create a priority list and work the list from

will have a major effect on the design of the protection plan. In addition to the strike pulses, the antennas and feed lines form tuned circuits that will ring when the pulses hit. This is much like striking a tuning fork in that ringing is created from the lightning’s pulsed energy.

Average peak current for the first strike is approximately 18 kA (98% of the strikes fall between 3 kA to 140 kA). For the second and subsequent impulses, the current will be about half the initial peak. Yes, there is usually more than one impulse. The reason that we perceive a lightning strike to flicker is that it is composed of an average 3 to 4 impulses per lightning strike. The typical interval between impulses is approximately 50 ms.

### Vulnerability

Frequently, amateurs provide an inducement for Mother Nature to find us. For good long distance communications, we put our antennas on the top of towers and place the towers so that they protrude above the surrounding buildings or countryside. While this provides for great signal coverage, it also makes it easier for Mother Nature to find a shorter, conductive path to ground.

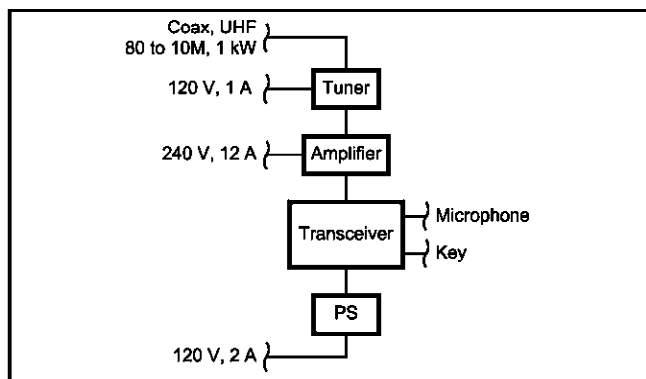

Figure 4—Block diagram of a typical simple HF radio station.

high to low priority. Probably first on the list are the more expensive items associated with your radio station, usually the transmitting and receiving equipment. Viewed another way, without these there is no radio station, so they should be very near the top of the list. What follows on the list depends on just how you enjoy the hobby—the antenna tuner, linear amplifier, terminal node controller, or computer. Further down the list might be the antenna, rotor and transmission line. Each person's list and priority ordering will be different. Pause here and mentally construct your priority list, being sure to include all the elements of your radio station. We will then work through the process of developing your protection plan.

The first step is to construct a complete block diagram of the equipment in your radio room starting with the top priority item. (You will make a separate plan for other areas needing protection.) This is usually simple and straightforward. In some installations it may be necessary to look behind the equipment to determine precisely the connections between each element. The accuracy of the diagram is important in determining the nature and effectiveness of the protection plan.

I would imagine that the list's top priority items are your transmitter and receiver (or transceiver). If you have multiples of either, then they are probably listed in order of value. These are the heart of your radio station, so make them the starting point of protection plan which will in turn examine and diagram each element of the station.

Assuming your primary item is a transceiver, represent it in the block diagram as a single rectangle. Label it with the manufacturer's name and model number. If your primary equipment is a transmitter/receiver pair, then represent them as individual single rectangles.

Next, think about the antenna connection to the primary transceiver, transmitter, or receiver. If the connection goes directly to the external antenna, simply draw a line from the rectangle to the edge of the paper. However, if the antenna is connected to the equipment via a linear amplifier, antenna tuner, or a multi-position coax switch, add this (these) as separate rectangle(s) interconnected with the primary radio equipment. The feed line going to the antenna should still go to the edge of the paper. Label the feed line's lowest and highest frequency (MHz or band name), the maximum transmit power in watts (rounded up), and the type of connector and gender (UHF/PL-259 male or N-series male, for example).

Add a rectangle to the diagram for each additional transceiver, transmitter, amplifier, and receivers in your radio room. Be sure to show all interconnections and antenna connections for each of these secondary rectangles. If any of the secondary radio equipment has a direct connection to an antenna, show the feed line going to the edge of the page. Be sure to label each rectangle with the manufacturer's name and model

number and each feed line with connector type and gender, frequency range, and maximum transmit power. Figure 4 shows a block diagram for a simple station.

The block diagram should now have a rectangle representing each piece of radio equipment and accessories in the radio room. Each of the rectangles should have lines representing the interconnecting cables and feed lines. Each feed line that leaves the radio room and goes to an antenna or some tower-mounted electronics should be drawn to the edge of the page and labeled.

### A Close Look

Now it is time to examine each of the rectangles, one at a time, and to add to the diagram any other electronic devices (as rectangles), complete with the electrical connections and interconnections between them. Some of these will be easy and intuitive, while others will require a little more crawling around behind the equipment. Every connection must be included—this is important to the integrity of the solution. The only exception is a non-conductive fiber-optic connection.

To complete the diagram in an orderly fashion, pick a rectangle and answer all of the following questions for that rectangle. Then, pick another rectangle and do the same until all of the rectangles have been examined.

Is there a connection between this rectangle and any other rectangle? If so, add a line between the respective rectangles and label its function.

Is there a connection between this rectangle and a device not yet included on the block diagram? This can include standalone amplifiers, power supplies, computers, terminal node controllers, modems, network routers, network hubs, and the like. If so, add the new device to the diagram as a rectangle and label it. Then add and label the connections. Repeat this step until all connections from this rectangle to new devices have been completed.

Is there an ac power connection required for this rectangle? If so, draw a line to the edge of the page and label it with the voltage and current required.

Is there a requirement to supply ac or dc power through a feed line to operate remote switches or electronics? If so, label the feed line at the edge of the page with the peak voltage and current requirements.

Are there control lines leaving the rectangle going to remote electronics, relays, or rotors? If so, draw a line to the edge of the page and label it appropriately.

Is there ac power leaving the rectangle going to the tower for safety lighting, convenience outlets, crank-up motors, or high-power rotors? If so, draw a line to the edge of the page and label it with the voltage and current required.

Is there a connection to a telephone line, ISDN telephone circuit, DSL telephone circuit, or cable connection (RF, video or data) for this rectangle? If so, draw a line to the edge of the page and label it appropriately.

Is there a connection to another antenna system such as for GPS, broadcast or cable TV, or DBS dish for this rectangle? If so, draw a line to the edge of the page and label it appropriately.

Is there a connection to other equipment elsewhere in the house or building, such as network or intercom cabling? If so, draw a line to the edge of the page and label it appropriately.

Once you have completed the process for each of the rectangles, including all of the new ones that were added, you should have an accurate block diagram of your radio station. It may be prudent to review each rectangle to verify that nothing was left out. Your block diagram should look something like Figure 5.

Now step back and physically look at the equipment in the radio room. Has every piece of equipment been reflected in

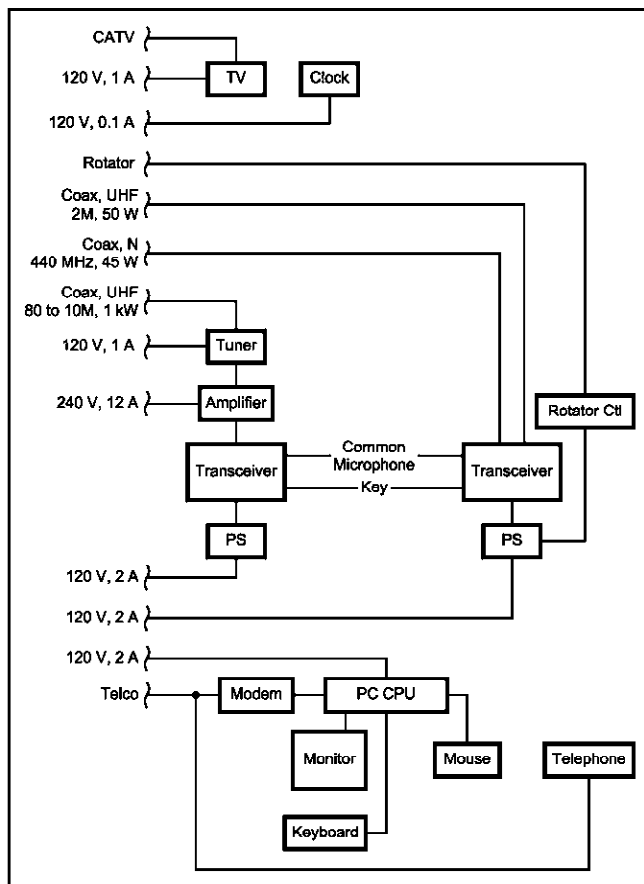

Figure 5—Block diagram of a typical more-complex radio station.

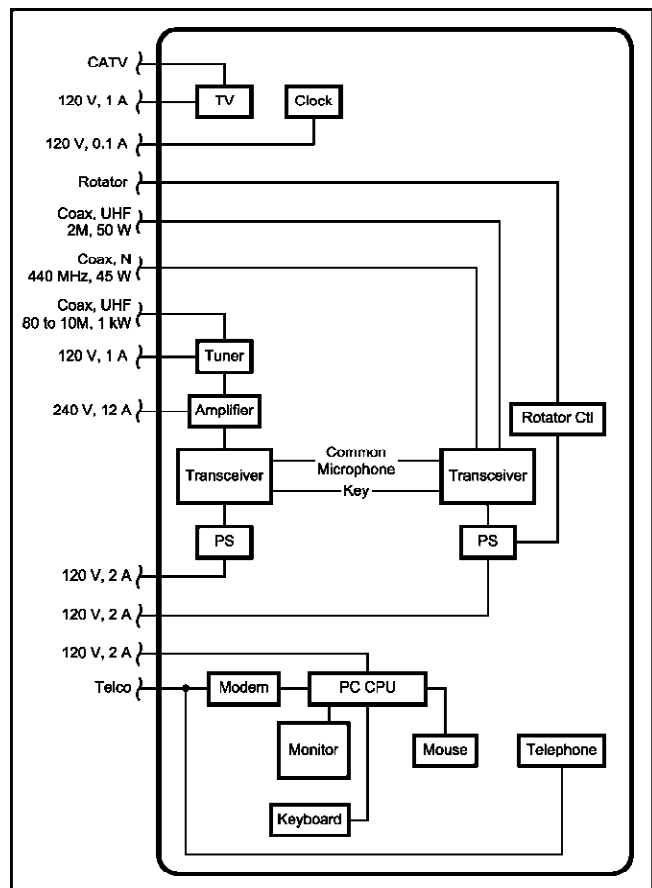

Figure 6—Lines that penetrate the circle are the radio station I/O circuits that must be protected.

the block diagram? Every metallic item within four feet (in all directions) of the radio equipment must be considered as a part of the radio equipment even if it is not electrically connected to it. If there is such an item that has not been included, we need to carefully examine it. An example of such a device could be a simple stand-alone telephone on the operating desk or a computer system (CPU, monitor, keyboard and mouse) some part of which is sitting on or near the radio desk.

Nearby devices (telephone and or computer), while electrically not a part of the radio station, are within a spark-gap of the radio station equipment and therefore considered proximally connected to the radio station and must be added to the block diagram. Follow the same procedure that you used to add equipment to the block diagram. As an example, Figure 5 also shows a computer that is included in the protection plan, but not directly connected to radio equipment.

Now that the diagram is accurate and complete, draw a circle around all of the rectangles allowing each of the lines that extend to the edge of the page to cross the circle as shown in Figure 6. The equipment represented by the rectangles within the circle is to be protected. All of the lines going from the circle to the edge of the page are called I/O (Input/Output) lines or circuits.

### All or Nothing

One word of caution regarding the accuracy and attention to detail; the protection is all or nothing. If an I/O line is inadvertently missed then the protection plan is flawed and the damage could be worse than having no protection at all.

Please note: Just because equipment may survive a direct lightning strike, does not mean that you can. You *cannot* oper-

ate (touch) the equipment during a strike because *you* breach the protected equipment circle to the outside world. You are conductive, and it could hurt both you and your equipment.

Now that you have identified all of the I/O lines of the station, each must be protected and each of the I/O line protectors must be grounded and mounted in common. We will discuss how to do this in the next part of this article.

*Ron Block, KB2UYT, has been a distributor and consultant for PolyPhaser, a vendor of lightning protection systems, since 1989 and has completed The Lightning Protection Course by PolyPhaser. He is the chairman of the Amateur Radio Station Grounding forum at the Dayton Hamvention and has been a guest speaker at various Amateur Radio club meetings. He may be reached at 327 Barbara Dr, Clarksboro, NJ 08020; ron@wrblock.com. The author's brother, Roger, founder of PolyPhaser, reviewed this article for technical accuracy. QST*

## NEW PRODUCTS

### TRI-BAND H-T ANTENNA FROM MALDOL

◇ Designed to improve the performance of today's Amateur Radio hand-held transceivers that feature 220-MHz operation, Maldol's new MH-610 tri-band whip antenna covers 144, 220 and 444 MHz in a lightweight, durable package. The 14-inch whip is made from super-flex material—the stuff used in “unbreakable” eyeglass frames—and can withstand a tremendous amount of abuse.

Price: \$49.95. For more information, see your favorite Amateur Radio products dealer or contact NCG at 1275 N Grove St, Anaheim, CA 92806; tel 800-962-2611, fax 714-630-7024, [www.natcommgroup.com](http://www.natcommgroup.com). QST

Previous • Next New Products