

## 2021 ORR-Ez Cert

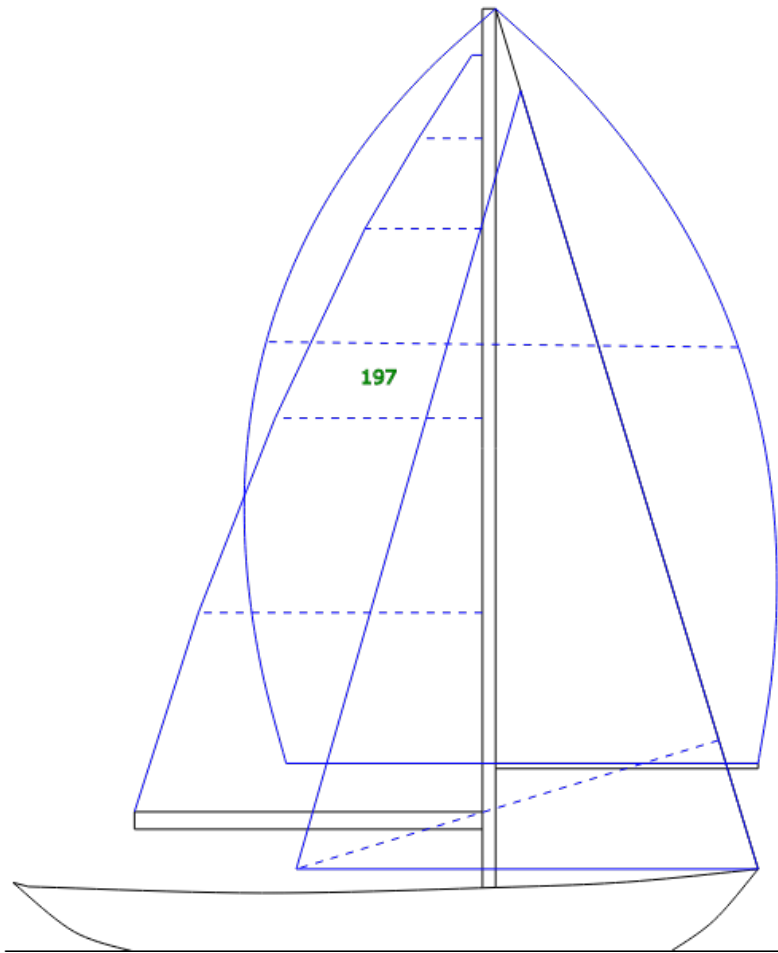

Yacht Name:	Laughing Gull
Class:	Alberg 30
Sail Number:	197
Builder:	
Owner(s):	Patrick Seidel
Configuration:	One Design
Certificate #:	EZ11136-OD-1
Issue Date:	2021-02-21
Valid Year:	2021
Offsets_file:	us30250.off
Cert Group:	ORR-Ez MIDATL
Rig Type:	Sloop
Forestay:	Masthead
Keel Type:	Fixed
Prop Type:	Fixed
Prop Install:	In Aperture
Prop Blades:	2
Prop Diameter:	0 ft
Spinnaker:	Symmetrical flown with spinnaker pole
Genoa/Jib Leech:	No Roach - Leech is straight
Large Roach Headsail:	No
Jib Furler:	No
Main Roller Furling:	No
LOA:	30.27 ft
LWL:	21.70 ft
Rated Length:	23.07 ft
Beam Max:	8.69 ft
Draft:	4.52 ft
Disp Empty:	9220 lbs
Disp Sailing:	0 lbs
Crew:	1040 lbs
Water Ballast:	0 lbs
Wetted Area:	217.3 ft²
LPS:	128.2 °
RM20:	387.9 ft-lbs
Stab Index:	133 °
Upwind SA/D:	18.92
D/Length:	378.5
Dnwind SA/D:	27.79



<b>Rig Dimensions</b>	<b>Jib/Genoa Meas.</b>	<b>Symmetric Spin. Meas.</b>	<b>Mainsail Meas.</b>
IG: 36.00 ft	LP: 18.09 ft	SL: 35.50 ft	HB: 0.43 ft
ISP: 36.00 ft	LPG %: 168.3 %	SMW: 19.33 ft	MGT: 2.62 ft
J: 10.75 ft	J Luff: 34.00 ft	SF: 19.33 ft	MGU: 4.81 ft
P: 31.00 ft	J Leech: 0 ft	Area: 571.9 ft²	MGM: 8.49 ft
E: 14.25 ft	Area: 307.5 ft²		MGL: 11.63 ft
SPL: 10.75 ft			Area: 256.3 ft²

	TOT (Spin)				TOT (Non-Spin)				TOD (Spin)				TOD (Non-Spin)			
	V.Light	Light	Medium	Heavy	V.Light	Light	Medium	Heavy	V.Light	Light	Medium	Heavy	V.Light	Light	Medium	Heavy
<b>RANDOM LEG</b>	<b>0.308</b>	<b>0.496</b>	<b>0.675</b>	<b>0.790</b>	<b>0.296</b>	<b>0.480</b>	<b>0.658</b>	<b>0.778</b>	<b>1,571.4</b>	<b>976.3</b>	<b>717.5</b>	<b>613.0</b>	<b>1,633.6</b>	<b>1,009.4</b>	<b>735.4</b>	<b>622.6</b>
<b>Closed Course</b>	TOT (Spin)				TOT (Non-Spin)				TOD (Spin)				TOD (Non-Spin)			
<b>W50/L50</b>	<b>0.292</b>	<b>0.481</b>	<b>0.676</b>	<b>0.807</b>	<b>0.288</b>	<b>0.477</b>	<b>0.672</b>	<b>0.804</b>	<b>2,011.1</b>	<b>1,222.2</b>	<b>869.9</b>	<b>728.6</b>	<b>2,040.0</b>	<b>1,233.4</b>	<b>874.6</b>	<b>731.2</b>
<b>W60/L40</b>	<b>0.295</b>	<b>0.481</b>	<b>0.667</b>	<b>0.786</b>	<b>0.293</b>	<b>0.479</b>	<b>0.665</b>	<b>0.785</b>	<b>2,030.4</b>	<b>1,245.9</b>	<b>899.2</b>	<b>762.6</b>	<b>2,050.2</b>	<b>1,252.9</b>	<b>901.7</b>	<b>763.6</b>
<b>Point to Point</b>	TOT (Spin)				TOT (Non-Spin)				TOD (Spin)				TOD (Non-Spin)			
<b>MOSTLY WW</b>	<b>0.312</b>	<b>0.492</b>	<b>0.649</b>	<b>0.737</b>	<b>0.311</b>	<b>0.491</b>	<b>0.648</b>	<b>0.736</b>	<b>1,934.6</b>	<b>1,227.6</b>	<b>930.1</b>	<b>819.3</b>	<b>1,940.2</b>	<b>1,230.1</b>	<b>931.6</b>	<b>819.6</b>
<b>MOSTLY LW</b>	<b>0.300</b>	<b>0.496</b>	<b>0.695</b>	<b>0.845</b>	<b>0.286</b>	<b>0.477</b>	<b>0.678</b>	<b>0.827</b>	<b>1,593.9</b>	<b>965.5</b>	<b>688.8</b>	<b>566.5</b>	<b>1,675.6</b>	<b>1,004.8</b>	<b>705.9</b>	<b>578.8</b>

Benchmark Ratings

	TOT (Spin)	TOT (Non-Spin)	TOD (Spin)	TOD (Non-Spin)
GPH	<b>0.668</b>		<b>802.2</b>	
IR#	<b>0.677</b>	<b>0.670</b>	<b>794.7</b>	<b>802.1</b>

Custom Ratings

	TOT (Spin)
Bayview MAC Shore	<b>0.663</b>
So Cal Offshore	<b>0.683</b>
So Cal Offshore Offwind	<b>0.681</b>