

15 HTS-VRT

Height: 21.5 in./546 mm

Width: 12.5 in./318 mm

Length: 22 in./559 mm

Item: 322840152

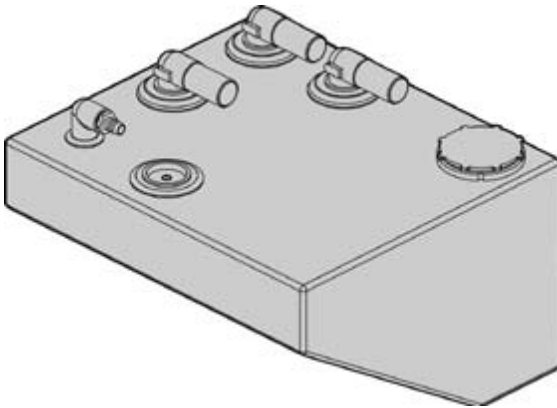

15 HTS-HRZ

Height: 15 in./381 mm

Width: 19 in./483 mm

Length: 22 in./559 mm

Item: 322840151

Complete, reliable holding tank systems for use with marine toilets.

Virtually any boat with room for a holding tank can now incorporate the advantages of Dometic's premium-quality Holding Tank Systems.

Leak-proof Design - Top-mounted hose connections eliminate standing liquid in discharge hose, preventing odor permeation through hose.

Odor-free, Highly Durable Tank - 100% virgin polyethylene resin with extra-heavy wall thickness prevents odor permeation and resists corrosion.

Implosion Protected - TankSaver® vacuum relief valve prevents damage from dockside pumps that use very high levels of vacuum.

ISO/USCG Compliant - SeaLand holding tanks fully comply with the ISO 8099:2000(E) standard and applicable U.S. Coast Guard requirements.

System Features:

- Heavy-duty 3/8" polyethylene
- TankSaver® relief valve
- Inspection port
- Inlet
- Vent outlet
- Two discharge outlets

Specifications:

Tank capacity: 15 gal. (57 L)

Empty weight: 25 lbs. (11.3 kg)

Full weight: 145 lbs. (65.8 kg)

Inlet fitting size: 1-1/2 in. (38.1mm)

Outlet fitting size: 1-1/2 in. (38.1mm)

Vent outlet size: 5/8 in. (15.9mm)

Dimensions: 15"H x 19"W x 22"D Horizontal

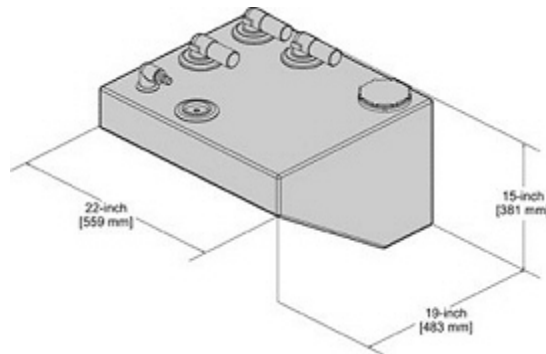

Tough Holding Tank

- 15 gallon
- 15"H x 19"W x 22"D Horizontal

Item #: 502987

Manufacturer: SEALAND

Model #: 322840151 / 15HTS-HRZ

Shipping Weight:  49.00 Lbs.

List Price: \$559.00

