

## Introducing the Raspberry Pi Model B+

Created by lady ada

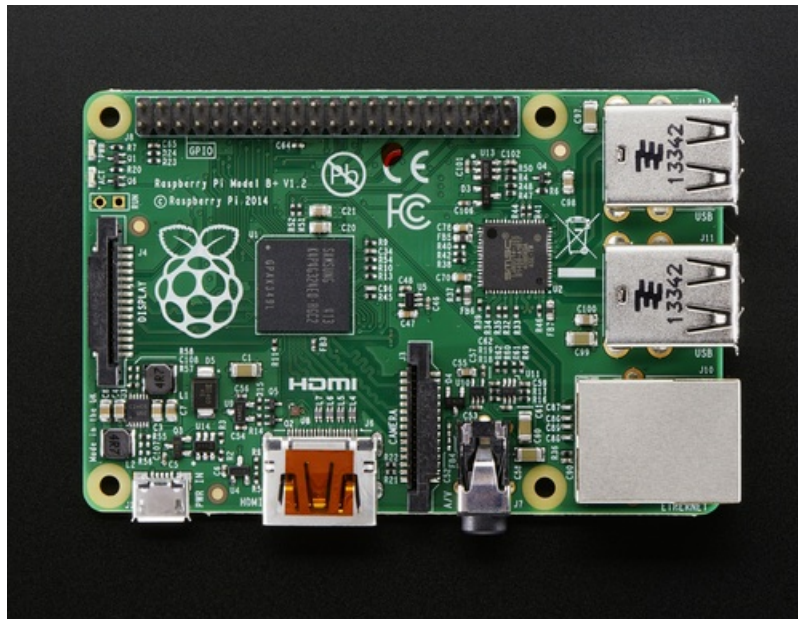

Last updated on 2018-08-22 03:42:32 PM UTC

## Guide Contents

Guide Contents	2
Overview	3
OMGOMGOMG ITS A NEW RASPBERRY PI!	3
A brief overview of what's new	4
What's not new	5
What does/doesn't work anymore	7
What does work!	7
What doesn't work	7
You may need a new Kernel/Firmware	7
GPIO Cables & Cobblers	7
Wolfson Audio Card & Other I2S (not I2C) Devices	9
Enclosures	9
Power Supply	10
Model A and B Power Supply	10
Model B+ Power Supply	11
GPIO Port	15
Model A and B (rev 1 & rev 2) GPIO	15
Raspberry Pi Model B+ GPIO Port	16
New GPIOs	16
USB Ports (Hub)	18
Don't forget! You need a new Kernel/Firmware	18
Audio/Video	20
Card Socket	22
Mounting Holes	25
What didn't change	27
F.A.Q.s	28
Hey I just got a Raspberry Pi Model B+ and the USB/Ethernet doesn't work!	28
Can I use a crummy 5V power supply?	28

## Overview

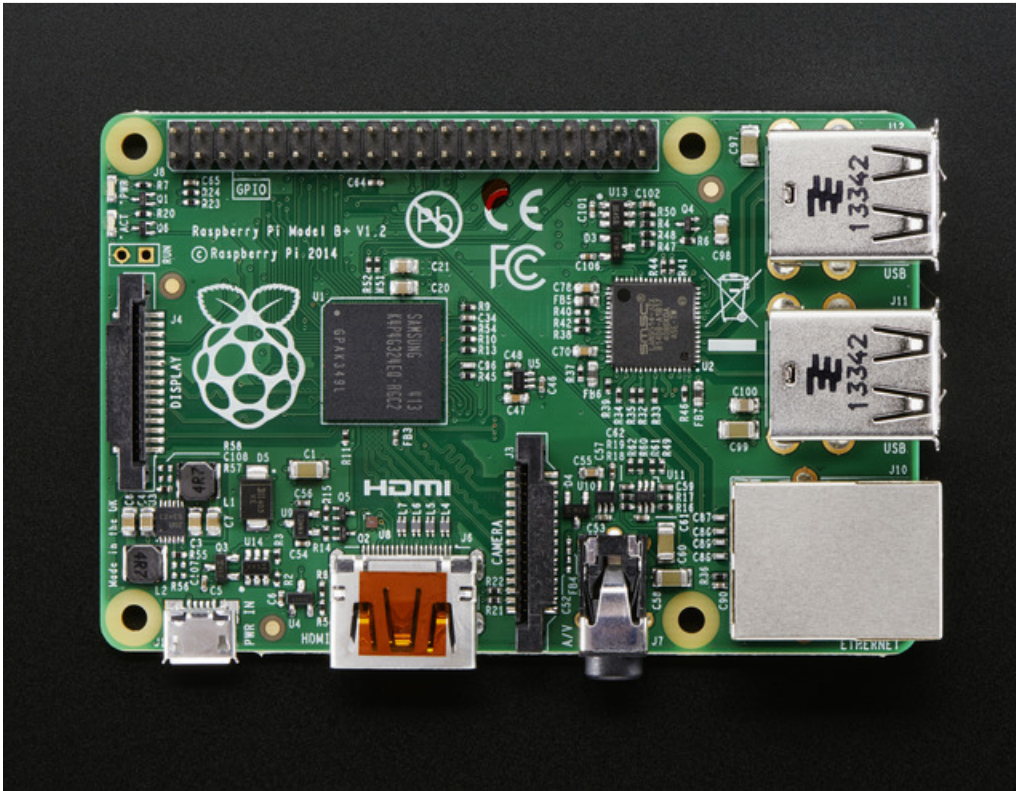

## OMGOMGOMG ITS A NEW RASPBERRY PI!

Yep, that's right, the fantastic engineers at Raspberry Pi HQ have blessed us with a new design. They've taken all the feedback over the last 3 years and rolled out a nice updated Pi with many fixes and extras...all at the same price!

Pick one up today at the [Adafruit shop!](https://adafruit.com) (<https://adafruit.com>)

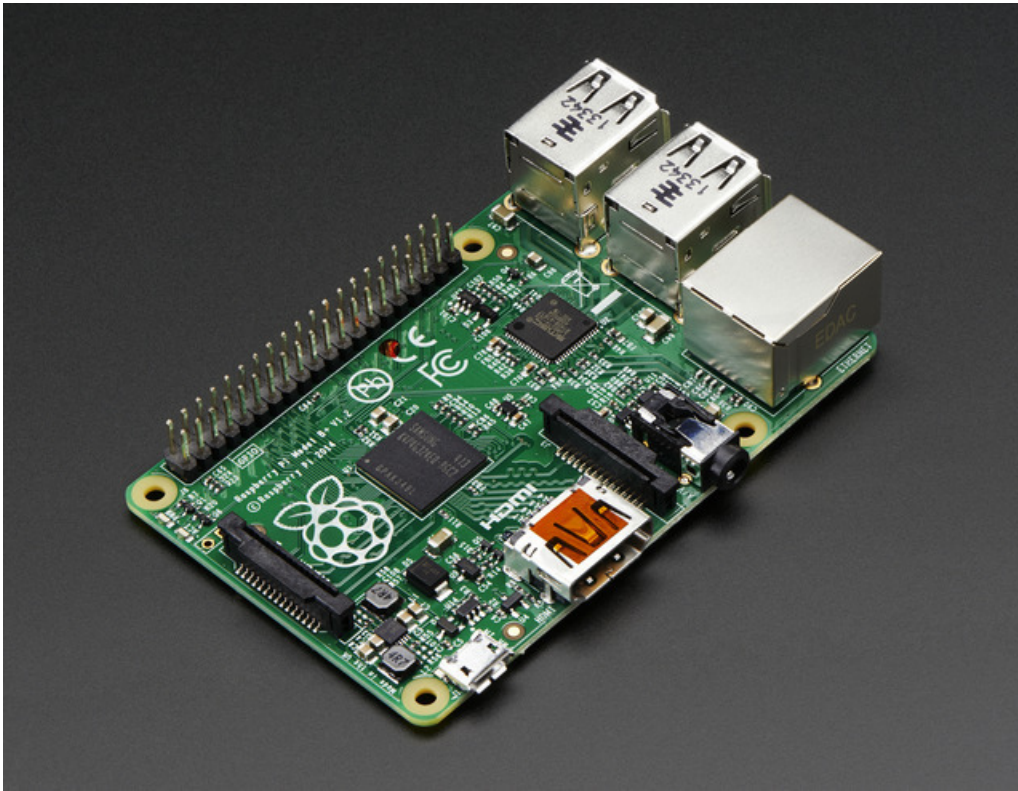

## A brief overview of what's new

---

- Dual step-down (buck) power supply for 3.3V and 1.8V
- 5V supply has polarity protection, 2A fuse and hot-swap protection
- New USB/Ethernet controller chip
- 4 USB ports instead of 2 ports
- 40 GPIO pins instead of 26. The top/first 26 pins match the original layout, 9 additional GPIO and 2 EEPROM Plate identification pins
- Composite (NTSC/PAL) video now integrated into 4-pole 3.5mm 'headphone' jack
- MicroSD card socket instead of full size SD
- Four mounting holes in rectangular layout
- Many connectors moved around



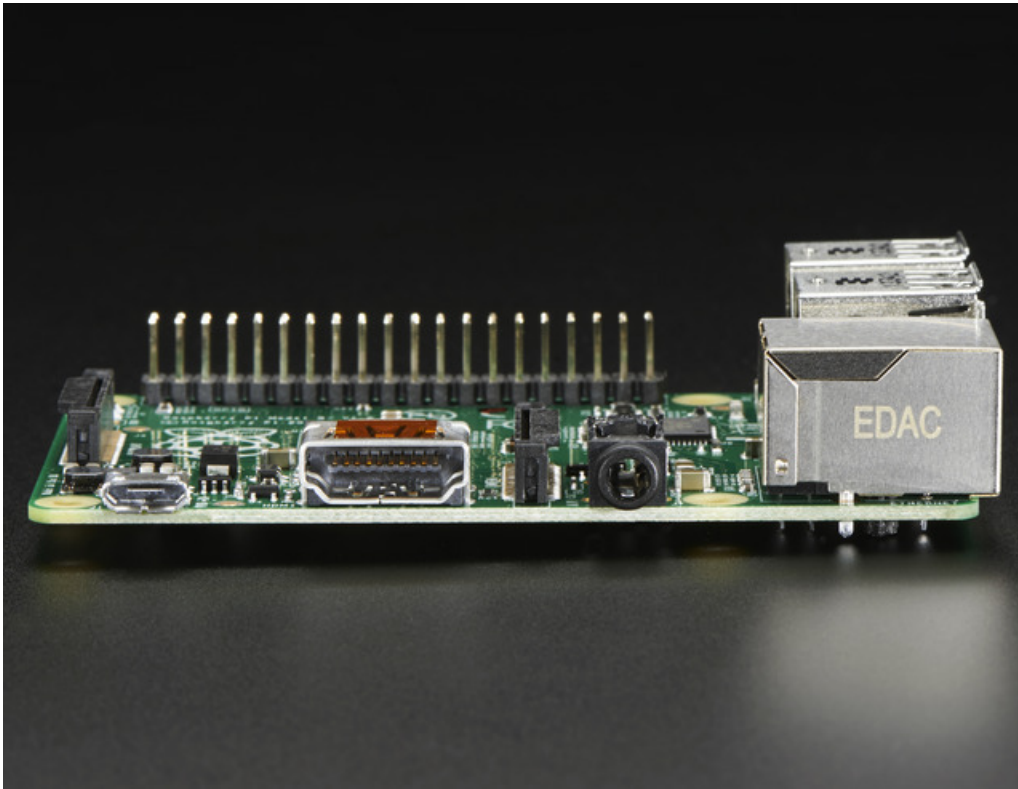

## What's not new

- Same basic size, 85mm x 56mm
- Same Processor, Broadcom SoC running at 700MHz (can be overclocked)
- Same RAM, 512MB soldered on top of the Broadcom chip

- Same power connector, microUSB
- Same software - identical operating systems will work fine, just make sure you have versions that are later than June 2014
- First 26-pins of GPIO are the same
- Same HDMI port
- Audio part of the A/V jack is the same
- Same Camera and DSI Display connector

## What does/doesn't work anymore

---

### What does work!

---

**Just about all our Pi plates work fine (except for the Wolfson Audio plates, see below!) They just may overhang the USB/Ethernet port side by 1/2cm**

- PiTFT - pinout and electric-wise it works and is tested, but our custom PiTFT kernel does not support the new USB/Ethernet chipset. We're working on it and hope to release a new version soon!
- 16x2 Character LCD plates (not tested yet but we're pretty confident it works)
- Proto Plate (not tested yet but we're pretty confident)

**Any USB-based devices, WiFi dongles, etc.**

**Any monitors that are HDMI based**

**Any displays that are NTSC-based** - they just need to have a proper A/V cable that brings out the 4th Video pin!

**Pi Cameras**

Any other cables, such as USB console cables, microUSB cables, Ethernet cables, HDMI to VGA adapters, USB hubs, power packs.

### What doesn't work

---

We'll try to keep track of all the things that would work with the model B that no longer does!

### You may need a new Kernel/Firmware

If you have an older Raspbian or NooBs or whatever (before ~ June 20 2014) do **asudo apt-get update** and **sudo apt-get upgrade** to update your kernel & firmware! Without new kernel/firmware, the USB/Ethernet chip doesn't work so make sure you do this on a Model B since you need to have ethernet or USB to work in order to download the files over the Internet!

### GPIO Cables & Cobblers

#1 thing is anything that using a 26-pin GPIO cable:



Even though the 'top 26 pins' are still compatible pinouts, IDC cables have a bit of a thicker part and the ends, so it will bump into the #27 and #28'th pins when you try to plug it in. If you're desperate, you can cut those two pins with diagonal cutters

This means that **Adafruit Cobbler**, **T-Cobbler**, **PermaProto Pi** do not work anymore out-of-the-box.

However you (<https://adafru.it/dGZ>) can make them work (<https://adafru.it/dGZ>) if you have a 40pin->26pin 'downgrader' cable (<https://adafru.it/dGZ>)



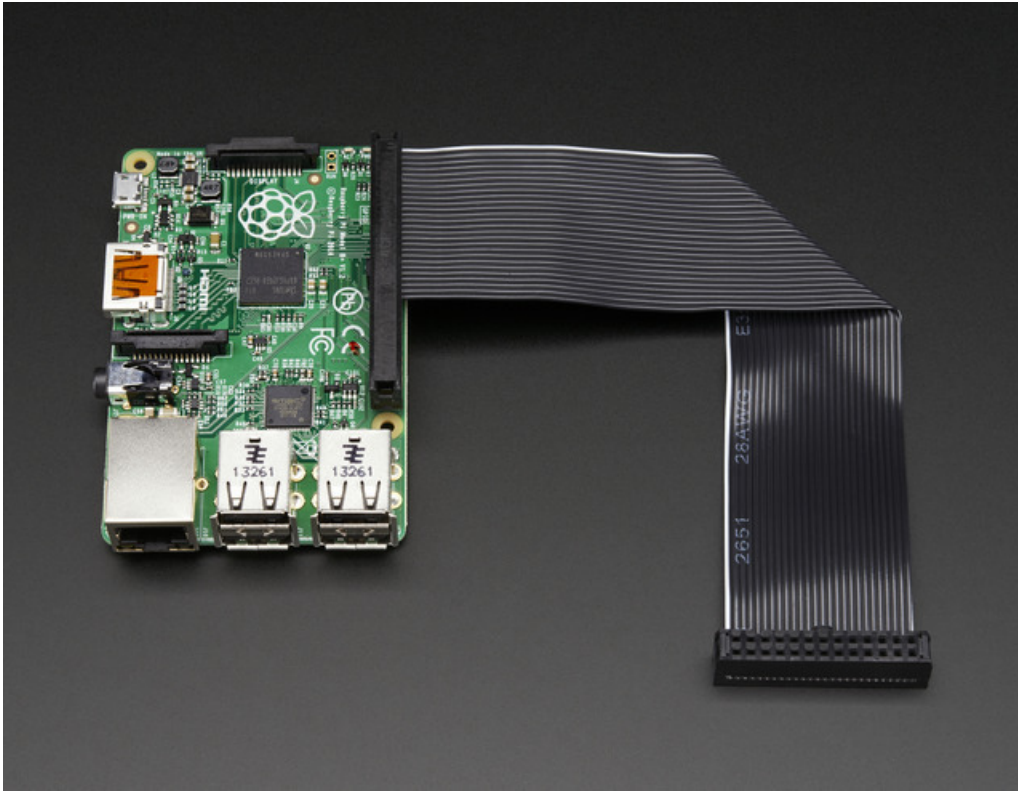

## Wolfson Audio Card & Other I2S (not I2C) Devices

These devices depend on the I2S pins that were next to the Pi GPIO header. Those pins are now on the 'main' GPIO header!

## Enclosures

We don't know of any old Model B enclosures that still work. Since the ports have switched around, and the mounting holes moved... unless the case specifically says it works with B+ it probably doesn't!

## Power Supply

One of the most exciting updates/upgrades of the new Model B+ is a fancy new power supply. The power supply of a computer is terribly boring sounding, but its really important. A good power supply makes everything hum along cleanly. A bad power supply causes hiccups, crashes, 'bricked' boards, SD card failures, USB failures...you name it!

## Model A and B Power Supply

The power supply is what takes the microUSB port voltage and creates the **5V USB**, **3.3V**, **2.5V** and **1.8V** core voltages. The 3.3/2.5/1.8 are for the processor and Ethernet.



Lets look at the 5V supply schematic first

USB Power Input 5V 700mA min

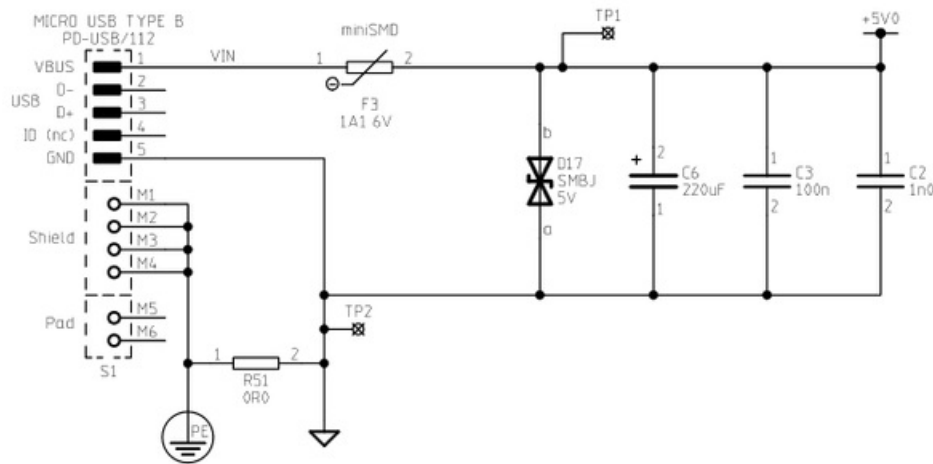

Power comes in from the LEFT side of the image, from a "MICRO USB TYPE B" jack, goes through "miniSMD" F3 (a fuse) and then has a D17 (Transient Voltage Protection Diode) across it as well as some capacitors (C2, C3 and C6). That voltage is the +5V0 USB bus voltage. Hurray!

There's a couple good things about this design:

- It's really inexpensive, allows the Pi Model B to be simple and low cost
- There's a TVS to protect against overvoltage/negative voltages (within a volt or two, its not a huge TVS, it wont protect against 120V or 220V mains!)
- There's a fuse to protect against over-current of about 1A

Not-so-great:

- If the voltage coming into the Pi microUSB port is NOT 5V, say 4V - the Pi 5V power pin wont be 5V, it will be 4V which is too low! There's no warning or 'repair' circuitry to fix the low voltage
- This can happen easily with a poor quality USB port that provides only say 4.5V or 4.75V coupled with a poor quality USB cable with very thin wires. The wires are so thin, that they act like *resistors* and there's a 'voltage drop'
- If the voltage is noisy or fluctuates, this can also be really annoying for the Pi or any USB devices plugged into it
- If you plug something into a USB port on the Pi, the sudden current draw will cause a brownout on the 5.0V line, resetting all the other USB devices (and possibly the Pi!)

Let's also look at the 3.3V, 2.5V and 1.8V power supplies

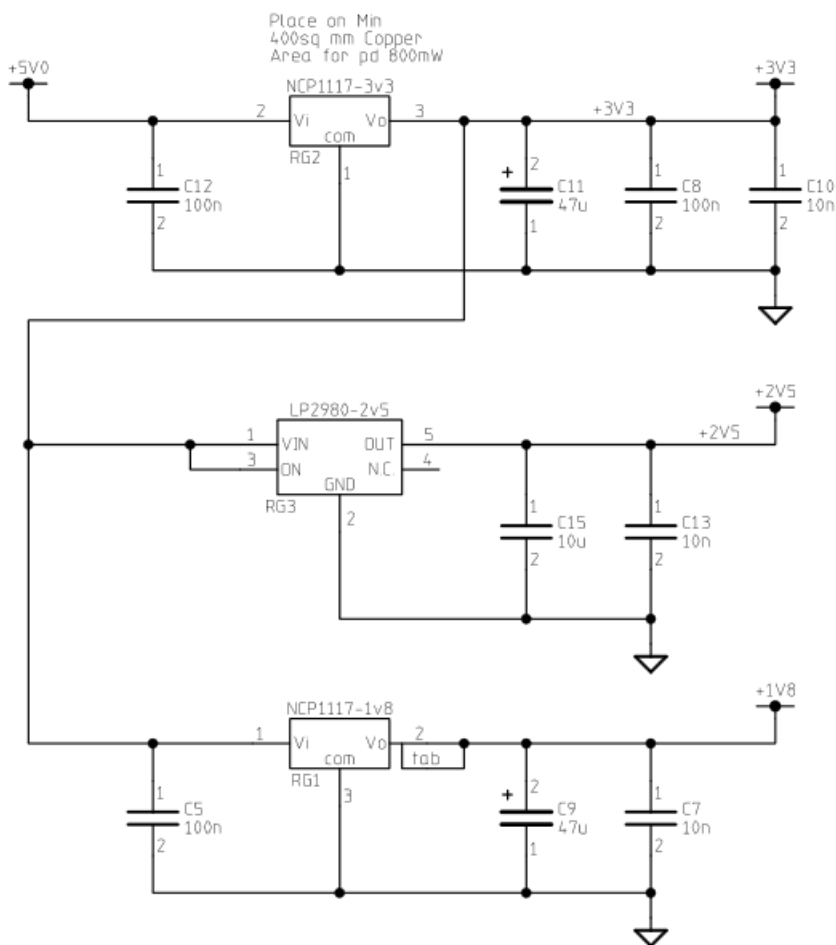

In the top left you can see that +5V0 voltage going into a NCP1117-3.3 (3.3V regulator), and the output of that going into a LP2980-2V5 regulator and NCP1117-1V8 regulator.

We're using the 5V power supply to generate the 3.3V supply, it does that by essentially 'eating' the  $5 - 3.3 = 1.7V$  difference and dissipating the power difference in heat. This is why the big chunky 3.3V regulator gets kinda hot (but don't worry, it does not get so hot it is damaging, its just burning off that extra voltage difference in heat)

## Model B+ Power Supply

To make the B+ more reliable and actually reduce the current draw, the power supply is completely redesigned.

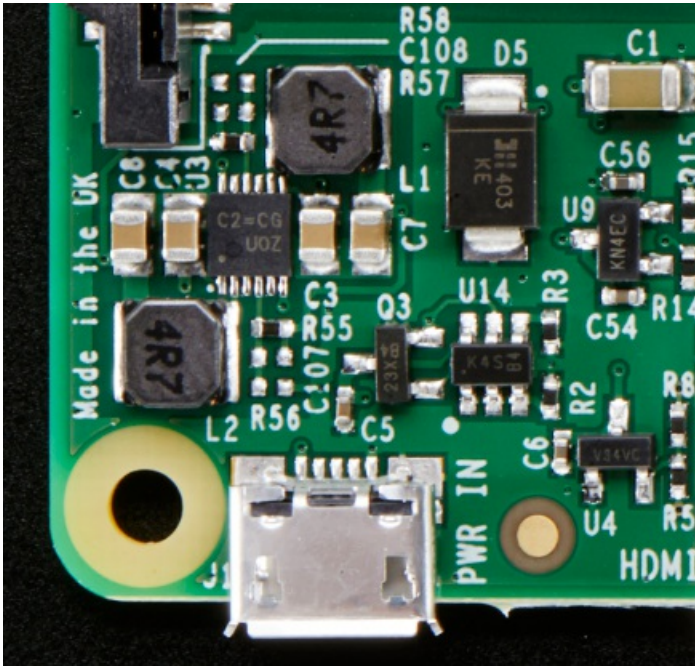

Lets look at the power supply input first

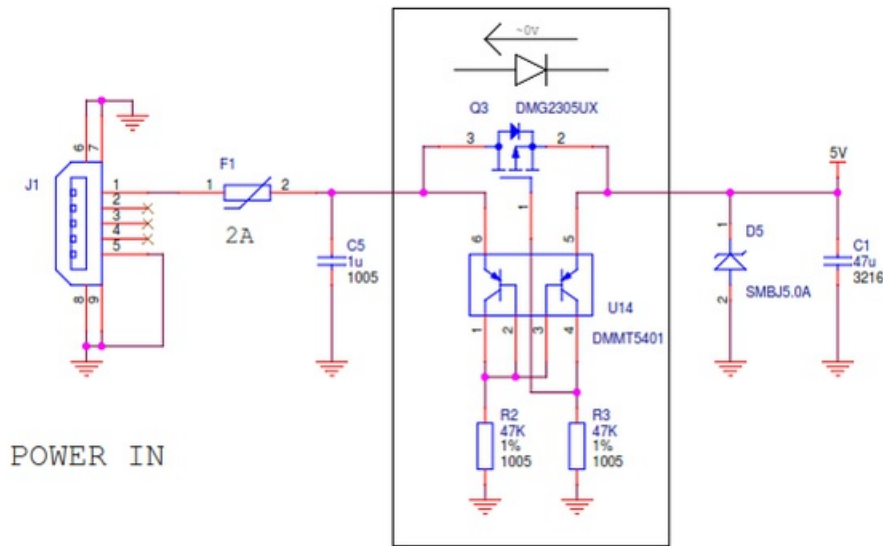

There's still the microUSB jack on the left, and the 1A fuse has been upgraded to a 2A fuse. There's also a [DMG2305UX](https://adafruit.it/dGU) P-Channel MOSFET. This acts as a polarity protection switch but is much lower 'drop-out' than a diode. It has only 52mΩ resistance so @ 2A its about 0.1V voltage drop. Most diodes would be at least 0.5V.

Watch this great video about this technique here:

To the right is a protection TVS diode (D5 part #SMBJ5) which protects from over-voltages. So not a lot has changed here (other than putting in a protection FET)

There *is* a PNP-matched-pair action going on around the polarity FET, but its 3AM and I'm not 100% sure what it's for so I'll wait till I get some rest before doing any analysis.

Let's look at the 3.3V & 1.8V supplies:

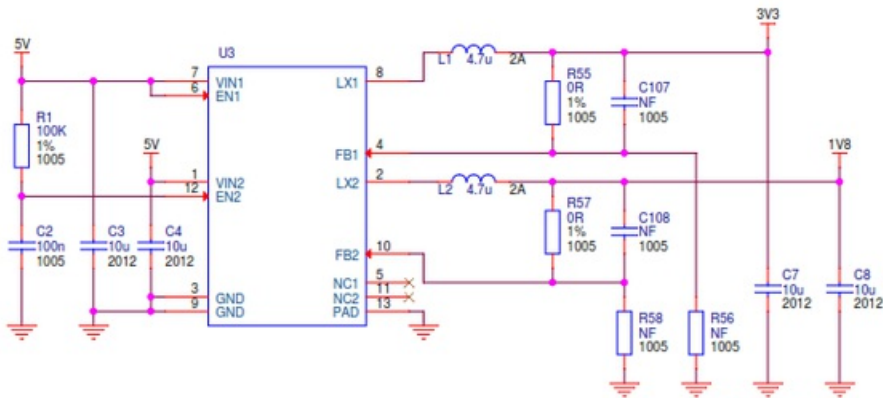

Instead of heat-spewing LDO (low dropout) regulators, we now have a dual *buck* converters. These are high efficiency converters that can take 5V down to 3.3V or 1.8V without as much heat loss. They're more expensive than LDO's but not terribly so!

The input to the dual buck is 5V (VIN1 and VIN2) - there's no part number marked here for some reason but it has 12 pins, is a DFN-shaped part (I deal with DFN's all day so I can spot them), and has the marking code **C2=CGU0G**. with some searching around for a 12-DFN dual buck with 1.8V and 3.3V fixed outputs...







Keywords:

- In stock
- Lead free
- RoHS Compliant

[Product Index](#) > [Integrated Circuits \(ICs\)](#) > [PMIC - Voltage Regulators - DC DC Switching Regulators](#)

Results matching criteria: 10

10 results, sort by price...

Compare Parts	Image	Digi-Key Part Number	Manufacturer Part Number	Manufacturer	Description	Quantity Available	Unit Price USD	Minimum Quantity	Packaging
<input type="checkbox"/>		<a href="#">RT8020AGQW-ND</a>	<a href="#">RT8020AGQW</a>	<a href="#">Richtek USA Inc</a>	IC REG BUCK SYNC 1A DL 12WDFN	0	<a href="#">0.48048</a>	2,500 Non-Stock	Tape & Reel (TR)
<input type="checkbox"/>		<a href="#">576-3276-2-ND</a>	<a href="#">MIC2238-GSYMLTR</a>	<a href="#">Micrel Inc</a>	IC REG BUCK SYNC 0.8A DL 12MLF	0	<a href="#">0.74841</a>	5,000	Tape & Reel (TR) <a href="#">Alternate Packaging</a>
<input type="checkbox"/>		<a href="#">AS1346-BTDT3318TR-ND</a>	<a href="#">AS1346-BTDT3318</a>	<a href="#">ams</a>	IC REG BUCK SYNC DL 12TDFN	0	<a href="#">1.17306</a>	1,000 Non-Stock	Tape & Reel (TR) <a href="#">Alternate Packaging</a>
<input type="checkbox"/>		<a href="#">576-3280-2-ND</a>	<a href="#">MIC2238-GSYMLTR</a>	<a href="#">Micrel Inc</a>	IC REG BUCK SYNC 0.8A DL 12MLF	0	<a href="#">1.98314</a>	5,000	Tape & Reel (TR) <a href="#">Alternate Packaging</a>

And look at the least expensive option (only 40 cents!) marking details...

RT8020AGQW

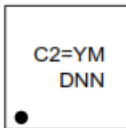

C2= : Product Code  
YMDNN : Date Code

Looks like its an [RT8020AGQW](https://adafruit.it/eIW) (<https://adafruit.it/eIW>)1A-max dual step-down converter with high 1.5MHz frequency. Nice chip! Its up-to-95% efficient, so less current is drawn to run the 3.3V power rail

There's one last piece that looks new, there's now a new part between the 5V input and 5V output called AP2331

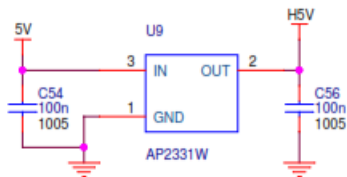

This is a hot-swap protector for the 5V supply. While it's not clear what H5V goes to, it seems likely that since the description says:

The AP2331 is single channel current-limited integrated high-side power switches optimized for hot-swap applications. The devices have fast short-circuit response time for improved overall system robustness and provide a complete protection solution for application subject to heavy capacitive loads and the prospect of short circuit. It offers reverse-current blocking, over-current, over-temperature and short-circuit protection, as well as controlled rise time and undervoltage lockout functionality.

that it is used to keep the USB hot-swap power draws from resetting the main 5V power supply. Hopefully this means you can plug-unplug USB devices like WiFi adapters without them resetting the Pi.



## GPIO Port

One of the biggest (and most noticeable) differences is now there's a **40-pin** GPIO port instead of **26-pin**

## Model A and B (rev 1 & rev 2) GPIO

Here's the GPIO port we know and love:

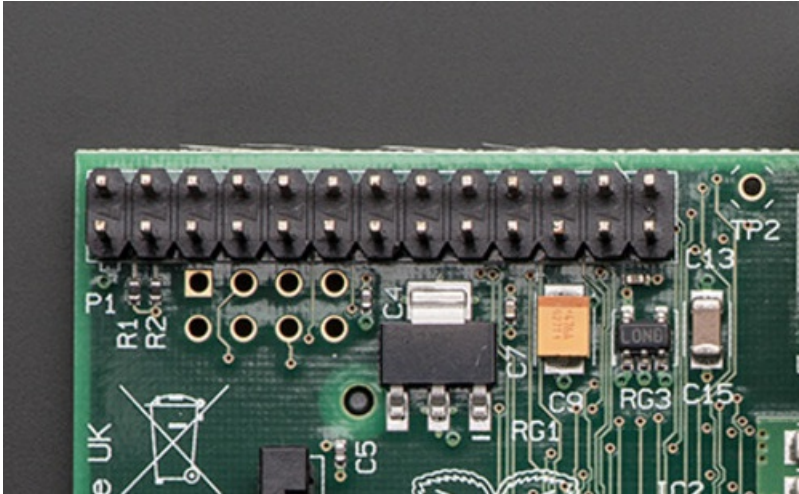

Here's the new one:

# Raspberry Pi Model B+ GPIO Port

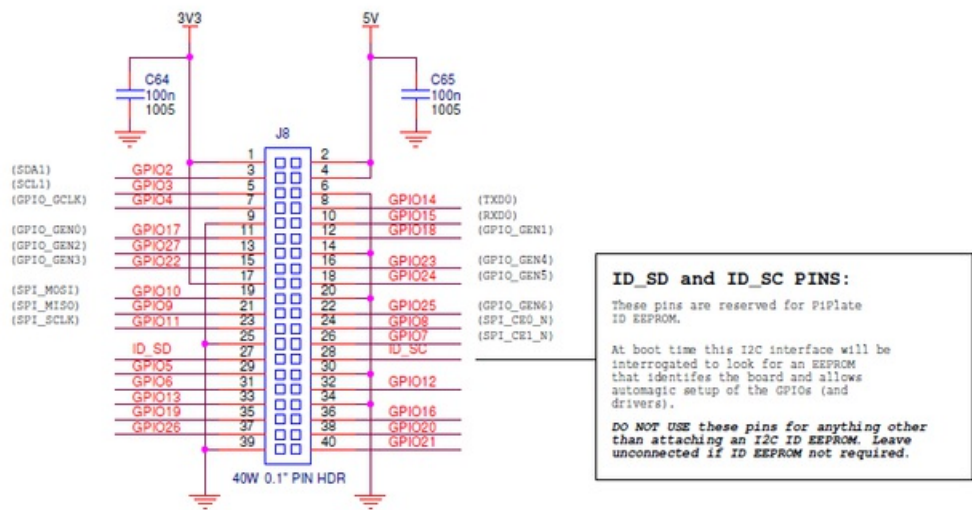
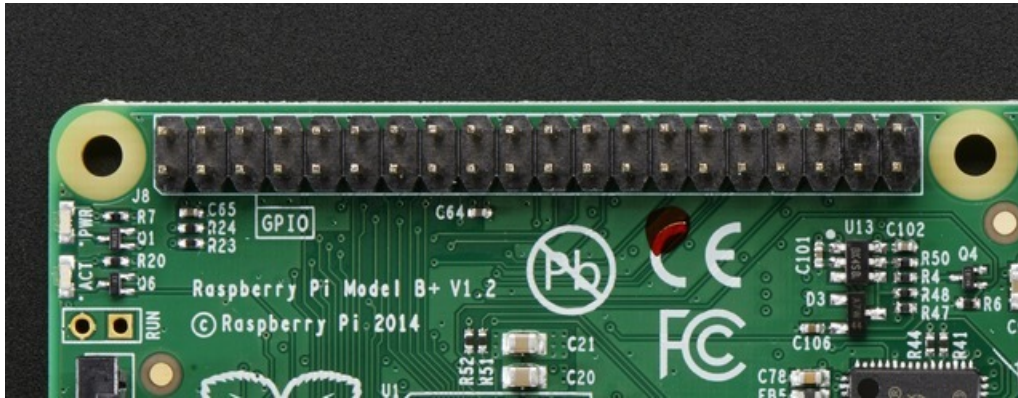

First thing to notice, the top 26 pins of the 40-pin connector are the same as the original. That means that most/many Pi Plates that plug into the Model B will plug into the B+ just fine. They won't sit in the same location - they'll be slid down just a bit but electrically-wise it's the same.

## New GPIOs

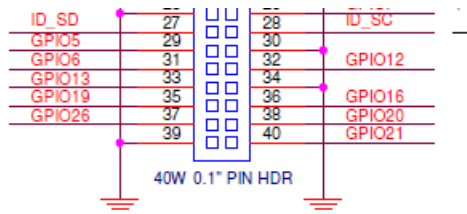

For people who love to attach sensors, buttons, displays and other accessories, there's good news: there's **9 more GPIO pins!** Yay!

There's also a pair of odd pins, **ID\_SD** and **ID\_SC**. The note says they are reserved for PiPlate ID EEPROM! What's that

mean? Sounds like the Pi foundation took a hint from the BeagleBone Black design for BBB capes. [The BBB capes all have a shared I2C bus for a classic 24LC type EEPROM. \(https://adafru.it/dGW\)](#) When the BBB boots, it reads the EEPROM and configures the bone inputs and outputs and kernel modules, etc. based on the EEPROM contents.

The ID pins are likely the same, its a secondary I2C port that looks just for these identifying EEPROMs. That way the Pi knows what Pi Plate is attached.

## USB Ports (Hub)



What's that, **four** USB ports on the new Model B+? That's right! The new Pi has even more USB ports. [The original B had a 2-port hub + Ethernet controller, the LAN9512 \(<https://adafru.it/dGX>\)](#), which basically turned the 1 USB port on the processor into 2 ports + Ethernet.



The new B+ upgrades the LAN9512 to the [LAN9514 - a 4-port USB Hub w/Ethernet \(<https://adafru.it/dGY>\)](#). This replacement makes it possible to plug in mouse, keyboard, USB WiFi and maybe even something else all at once.

## Don't forget! You need a new Kernel/Firmware

If you have an older Raspbian or NooBs or whatever (before ~ June 20 2014) do **asudo apt-get update** and **sudo apt-get upgrade** to update your kernel & firmware! Without new kernel/firmware, the USB/Ethernet chip doesn't work so make sure you do this on a Model B since you need to have ethernet or USB to work in order to download it, eh?



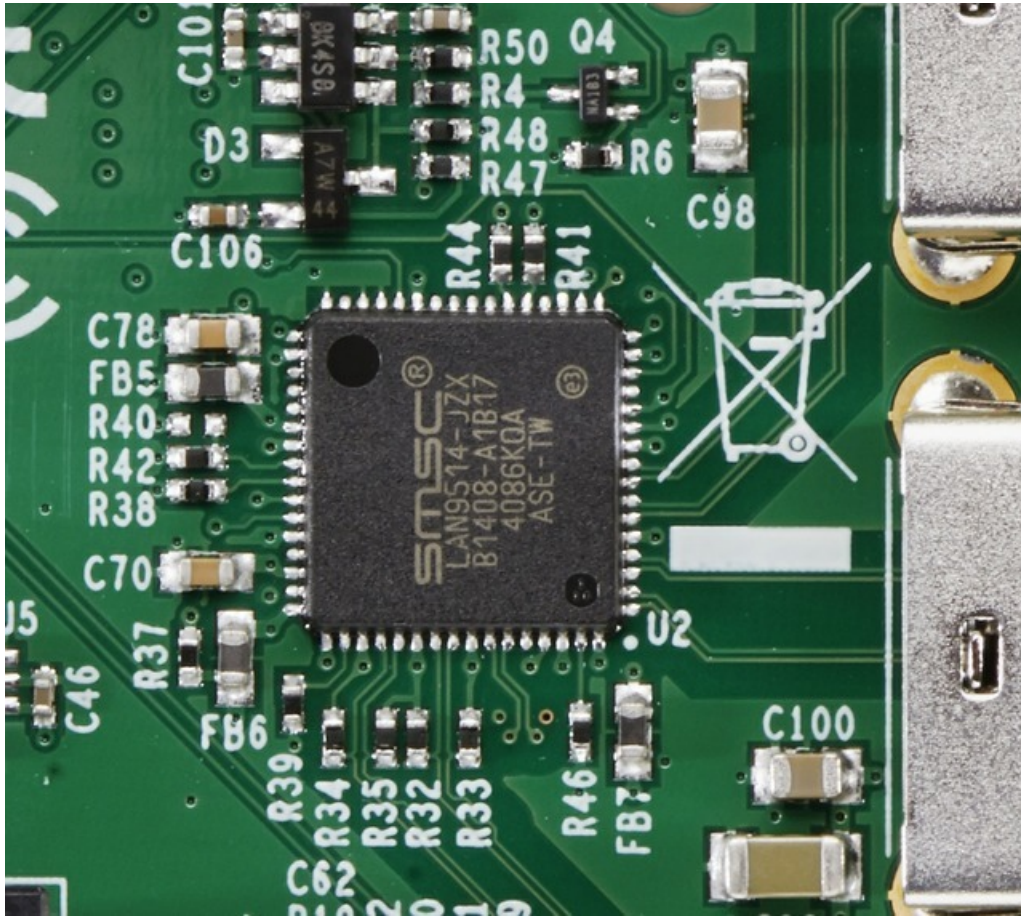

## Audio/Video

In order to make space for the second set of USB ports, and the extended GPIO slot, the Composite video port (Yellow RCA block connector) got the chop.

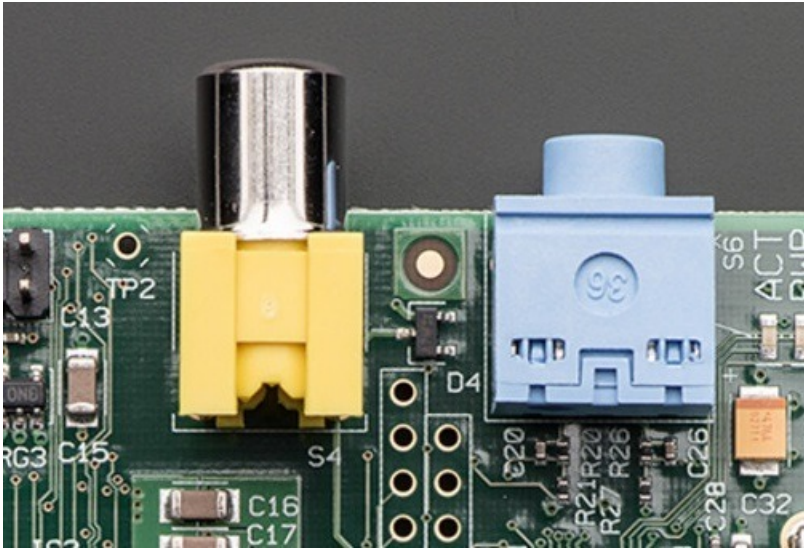

The blue (or black) headphone jack also got a little bit of reworking, instead of being large and chunky it's now quite svelte!

According to Pi Team there's also an improved audio power supply so the audio output sounds nicer - we don't have a schematic from the Pi Foundation yet, so we don't know precisely what changed

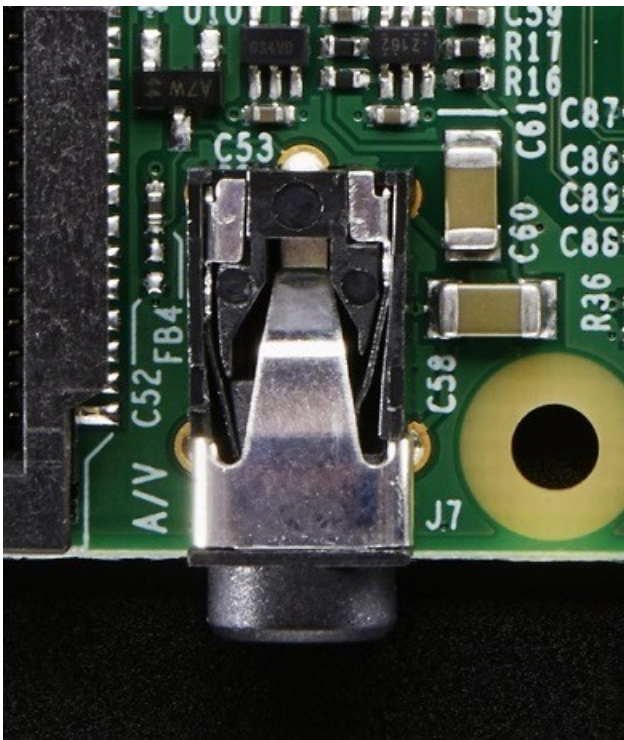

The nice thing about this jack is that its a **4-pole (TRRS)** type connector. If you plug in stereo headphones it will work like a headphone jack. If you plug in an A/V cable like this:





You'll get stereo (red and white) plus video on the yellow cable.

If you're recycling some older cable - you may have to experiment with which cable color is which output. Different camcorders/iPods had different pinouts for audio vs video so don't be surprised if "white" is video and "yellow" is audio. It is not harmful to experiment as the voltage levels for video and audio are similar.

## Card Socket

Like the Model A & B, the B+ requires a FLASH card to store the operating system and files. The Model A and B had an SD socket on the bottom:

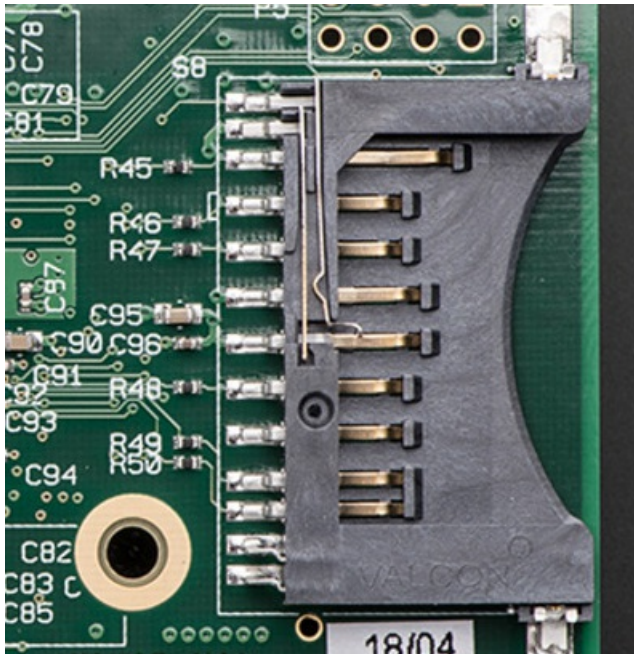

The SD card stuck out the end of the Pi, and could come loose or snap off by accident with enough force.

The new B+ replaces the large SD socket with a new MicroSD socket

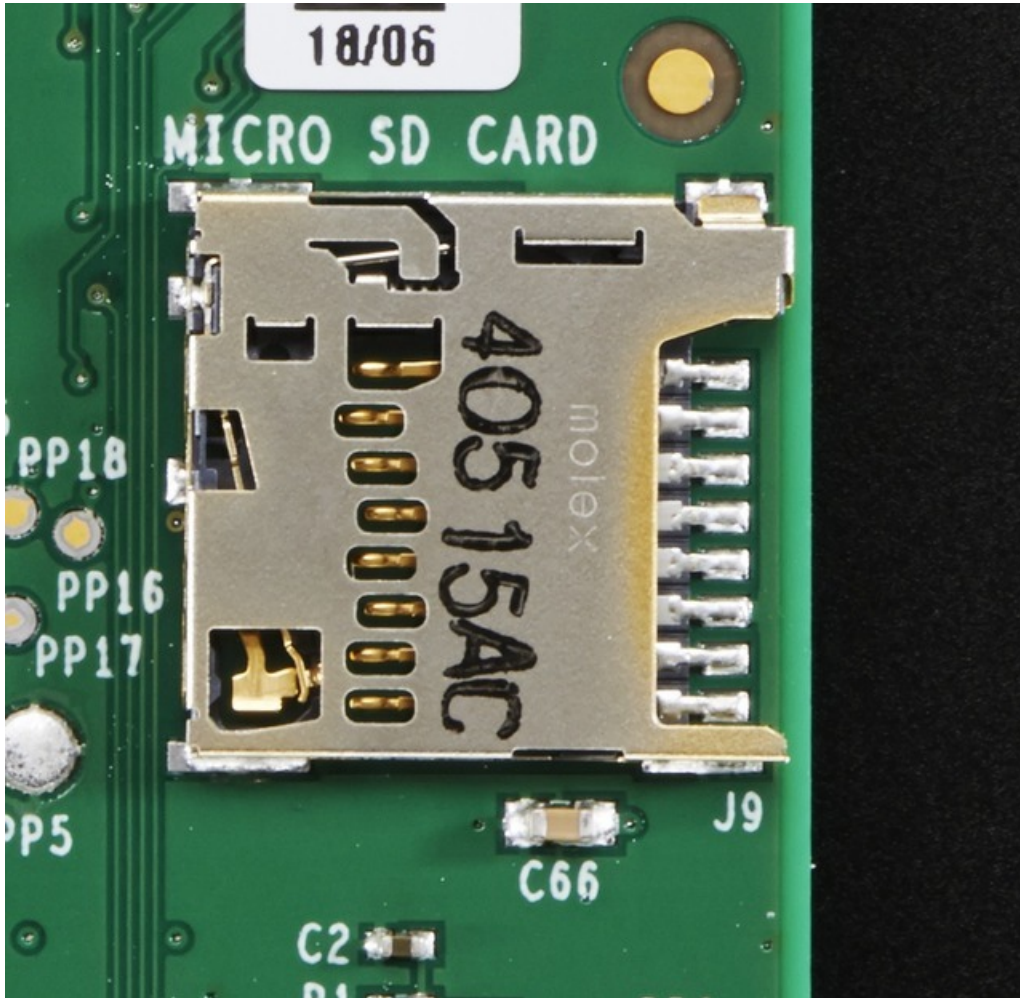

The good news for any Adafruit customers, we always had dual Micro/Standard SD cards so you can still use the same cards! Just discard the adapter.

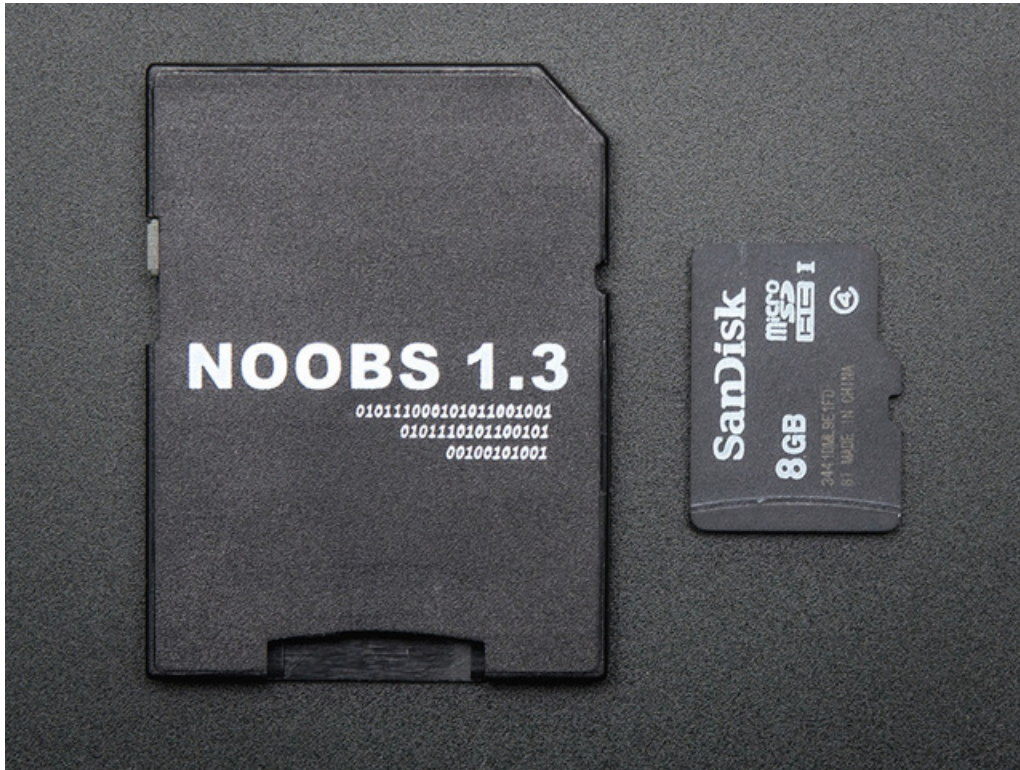



## Mounting Holes

If you'd like to attach the Pi to something, you've got 4 options now!

The original Model B v1 had no mounting holes at all (oof!)

The Model B Rev 2 and Model A came with two mounting holes

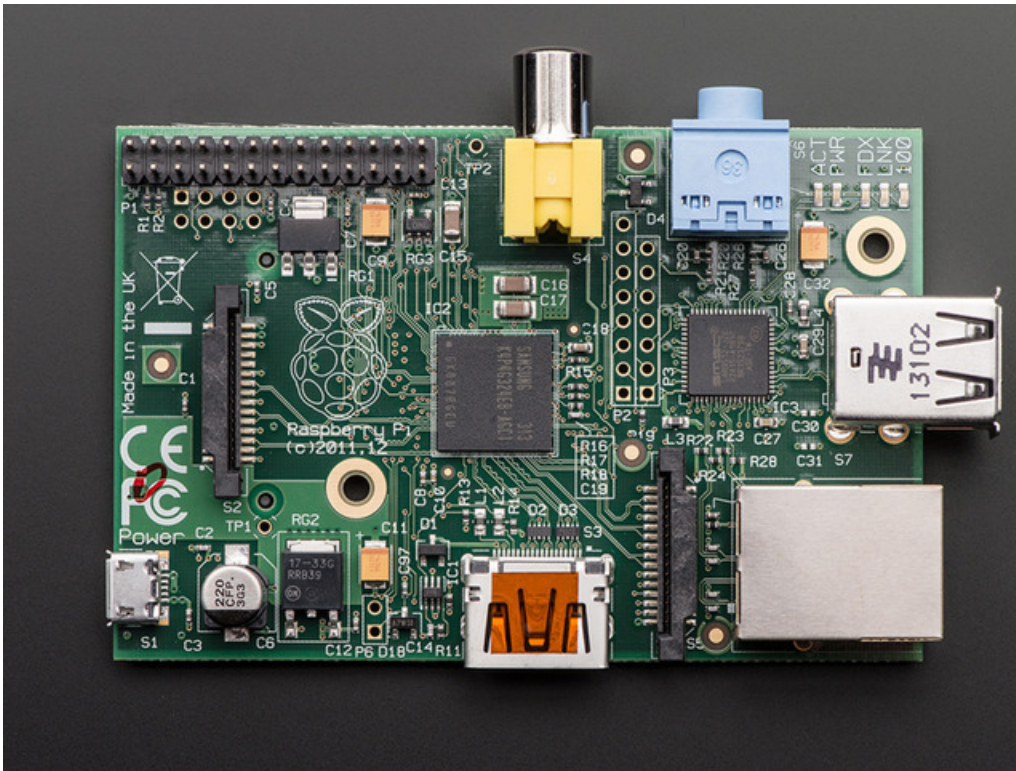

Now the model B+ has four!

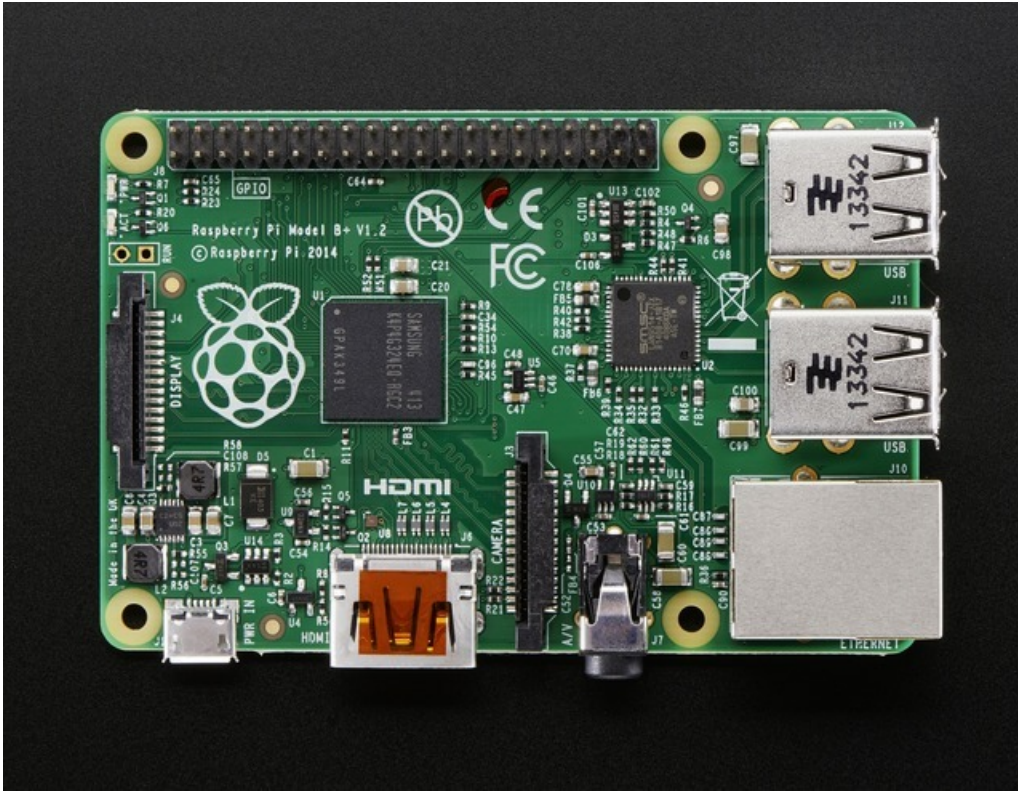

And they're in a rectangle

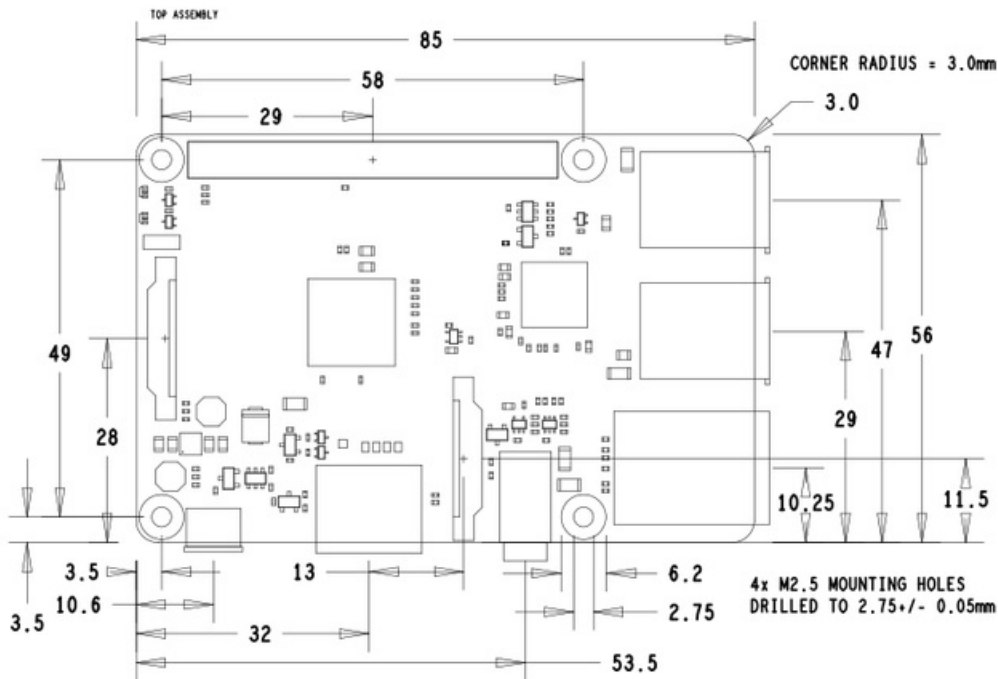

Note that if you have a mounting plate or case designed for the model B, its unlikely it will work with a B+! Check before purchasing!



## What didn't change

---

OK so a lot changed, but what didn't?

- Same basic size, 85mm x 56mm
- Same Processor, Broadcom SoC running at 700MHz (can be overclocked)
- Same RAM, 512MB soldered on top of the Broadcom chip
- Same power connector, microUSB
- Same software - identical operating systems will work fine
- First 26-pins of GPIO are the same
- Same HDMI port
- Audio part of the A/V jack is the same
- Same Camera and DSI Display connector

## F.A.Q.s

---

### Hey I just got a Raspberry Pi Model B+ and the USB/Ethernet doesn't work!

Your kernel/firmware (operating system) has to be updated to support the new USB/Ethernet controller chip! The annoying thing is that to upgrade you kinda need network connectivity which you can't get if USB/Ethernet is down. If you have a spare Model B around, try running

```
sudo apt-get update
sudo apt-get upgrade
```

To update to the latest kernel!

### Can I use a crummy 5V power supply?

No! We originally thought there might be a SEPIC/Buck-Boost 5V supply but there isn't! So if you're having power problems, make sure you have plenty o' solid 5V power and try a shorter micro USB cable. Long cables with thin wires are the bane of Pi!