

YANMAR

MARINE DIESEL ENGINE

MODELS:

2GM20(F)(V)(C), 3GM30(F)(V)(C)

EPA Certified Engine
It meets the low emission standards set by the EPA

OPERATION MANUAL

California Proposition 65 Warning

Diesel engine exhaust and some of its constituents are recognized by the State of California to cause cancer, birth defects, and other reproductive harm.

GB

Contents

CONTENTS

INTRODUCTION	3		
1 FOR YOUR SAFETY	4		
1.1 Warning symbols.....	4		
1.2 Safety Precautions	4		
1.3 Warning Labels	7		
2 PRODUCT EXPLANATION.....	8		
2.1 Use, Driving System etc.....	8		
2.2 Engine Specifications.....	9		
2.3 Names of Parts.....	15		
2.4 Major Servicing Parts	16		
2.5 Control Equipment	17		
2.5.1 Control Panel	17		
2.5.2 Single Lever Remote Control Handle	19		
2.5.3 Stopping Equipment	19		
2.5.4 Decompression Equipment.....	19		
3 OPERATION	20		
3.1 Fuel Oil, Lube Oil & Cooling Water....	20		
3.1.1 Fuel Oil	20		
3.1.2 Lube Oil.....	21		
3.1.3 Cooling Water	21		
3.2 Before Initial Operation	22		
3.2.1 Supply Fuel Oil.....	22		
3.2.2 Supply Engine Lube Oil.....	22		
3.2.3 Supply Clutch Lube Oil	23		
3.2.4 Supply Cooling Water	23		
3.2.5 Cranking (Idling)	24		
3.2.6 Check and Resupply Lube Oil and Cooling Water	25		
3.3 Operating your Engine	25		
3.3.1 Inspection Before Starting	26		
3.3.2 How to Start the Engine.....	27		
3.3.3 Operation	29		
3.3.4 Cautions during Operation.....	30		
3.3.5 Stopping the Engine	30		
3.4 Long term Storage	32		
4 MAINTENANCE & INSPECTION	34		
4.1 General Inspection Rules	34		
4.2 List of Periodic Inspection Items.....	35		
4.3 Periodic Inspection Items.....	37		
4.3.1 Inspection on Initial 50 Hrs. of Operation (or after 1 month)....	37		
4.3.2 Inspection Every 50 Hours (or monthly)	37		
4.3.3 Inspection Every 150 Hrs	39		
4.3.4 Inspection Every 300 Hrs	39		
4.3.5 Inspection Every 600 Hrs	40		
4.4 EPA Requirements	41		
4.4.1 EPA Certification Plate.....	41		
4.4.2 Conditions to Insure Compliance with Emission Standards.....	42		
4.4.3 Inspection and Maintenance ...	44		
4.4.4 Emission System Warranty Statement.....	44		
5 TROUBLE AND TROUBLESHOOTING	45		
6 PIPING DIAGRAMS.....	48		
7 WIRING DIAGRAMS.....	50		
APPENDIX A (Piping diagrams).....	A-1		
(See the back of this Manual)			
APPENDIX B (Piping diagrams)	B-1		
(See the back of this Manual)			

Introduction

Thank you for purchasing a YANMAR Marine Diesel Engine.

This Operation Manual describes the operation, maintenance and inspection of the 2GM20(F)(V)(C), 3GM30(F)(V)(C) Yanmar Marine Diesel Engines.

Read this Operation Manual carefully before operating the engine to ensure that it is used correctly and that it stays in the best possible condition.

Keep this Operation Manual in a convenient place for easy access.

If this Operation Manual is lost or damaged, order a new one from your dealer or distributor.

Make sure this manual is transferred to subsequent owners. It should be considered as a permanent part of the engine and remain so.

Constant efforts are made to improve the quality and performance of Yanmar products so some details included in this Operation Manual may differ slightly from your engine. If you have any questions about this, please contact your Yanmar dealer or distributor.

The marine gear described in this manual is Yanmar Model KM Series.

Operation Manual (Marine Engine)	Models	2GM20(F)(V)(C), 3GM30(F)(V)(C)
	Code. No.	499611 - 00680

With regard to the sail drive, this manual describes lube oil selection and specification only. Please read the Sail Drive Operation Manual, which is supplied with the Sail Drive Unit, for further information.



1. For your safety

1.1 WARNING SYMBOLS

Most operation, maintenance and inspection problems arise due to users' failure to comply with the rules and precautions for safe operation described in this operation manual. Often, users do not understand or recognize the signs of approaching problems. Improper handling can cause burns and other injuries and can result in death.

Be sure to read this operation manual carefully before operating the engine and observe all of the instructions and precautions described in this manual.

Below follow the warning signs used in this manual. Pay special attention to parts containing these words and signs.

 **DANGER**

DANGER indicates an imminently hazardous situation which, if not avoided, **WILL** result in death or serious injury.

 **WARNING**

WARNING indicates a potentially hazardous situation which, if not avoided, **COULD** result in death or serious injury.

 **CAUTION**

CAUTION indicates a potentially hazardous situation which, if not avoided, may result in minor or moderate injury.

This sign is also be used to alert against unsafe practices.

The descriptions captioned by **NOTICE** are particularly important cautions for handling. If you ignore them, the performance of your machine may deteriorate leading to problems.

1.2 SAFETY PRECAUTIONS

(Observe these instructions for your own safety!)

Precautions for Operation

 **DANGER**



Filler Cap of Fresh Water Tank

Never open the cap of the fresh water tank while the engine is still hot. Steam and hot water will spurt out and burn you seriously. Wait until the temperature of the fresh water tank has dropped, wrap a cloth around the filler cap and loosen the cap slowly. After inspection, refasten the cap firmly.

1. For your safety

⚠ DANGER



Battery

Never smoke or permit sparks near the battery, because it may emit explosive hydrogen gas. Place the battery in a well-ventilated place.

⚠ DANGER



Fuel

Use only diesel oil. Never use other fuels, including gasoline, kerosene, etc., because they could cause a fire. The wrong fuel could also cause the fuel injection pump and injector to fail due to lack of proper lubrication. Be sure to check that you have selected the correct diesel fuel before filling the fuel tank.

⚠ WARNING



Fire Prevention

Be sure to stop the engine and confirm that there are no open flames in the vicinity before supplying fuel. If you do spill fuel, wipe such spillage carefully and dispose of the wiping materials properly. Wash your hands thoroughly with soap and water.

Never place oil or other flammable material in the engine room.

Install a fire extinguisher near the engine room, and familiarize yourself with its use.

⚠ WARNING



Exhaust Gas

Exhaust gas contains poisonous carbon monoxide and should not be inhaled.

Be sure to install ventilation ports or ventilators in the engine room and ensure good ventilation during engine operation.

⚠ WARNING



Moving Parts

Do not touch or let your clothing get caught in the moving parts of the engine, such as the front drive shaft, V-belt or propeller shaft, during engine operation. You will be injured.

Never operate the engine without the covers on the moving parts.

⚠ CAUTION



Burns

The whole engine is hot during operation and immediately after stopping. The exhaust manifold, exhaust pipe and high pressure fuel pipe are very hot. Never touch these parts with your body or clothing.

1. For your safety

▲ WARNING



Alcohol

Never operate the engine while you are under the influence of alcohol. Never operate the engine when you are ill or feeling unwell.

SAFETY PRECAUTIONS FOR INSPECTION

▲ DANGER



Battery Fluid

Battery fluid is dilute sulfuric acid. It can blind you if it gets in your eyes, or burn your skin. Keep the fluid away from your body. If you touch it, wash it off immediately with a large quantity of fresh water and call your doctor for treatment.

▲ WARNING



Fire by Electric Short-Circuits

Always turn off the battery switch before inspecting the electrical system.

Failure to do so could cause short-circuiting and fires.

▲ WARNING



Stop the engine before servicing

Stop the engine before you service it.

Turn the battery switch off. If you must inspect while the engine is in operation, never touch moving parts. Keep your body and clothing well clear of all moving parts.

▲ CAUTION



Scalds

If extracting oil from the engine while it is still hot, don't let the oil splash on you.

Wait until the temperature has dropped before extracting cooling water from the engine. Don't let it splash on you.

▲ DANGER

Forbidden Modifications

Never release the limiting devices such as the engine speed limit, fuel injection limit, etc.

Modification will impair the safety and performance of the product and shorten product life.

Also note that any troubles arising from modification are not covered by our warranty.

▲ DANGER

Precautions for Treating Waste

Never dispose of waste oil or other fluid in a field, sewer, river, or the sea. Treat waste matters safely observing regulations or laws.

Ask a waste recovery company to collect it.

1. For your safety

SAFETY PRECAUTIONS FOR INSPECTION

1.3 WARNING LABELS

To insure safe operation, warning device labels have been attached. Their location is shown below and they should always be visible. Please replace if damaged or lost.

Warning Device Labels, Parts Numbers

No.	Part Code No.
①	128296-07350
②	128296-07260

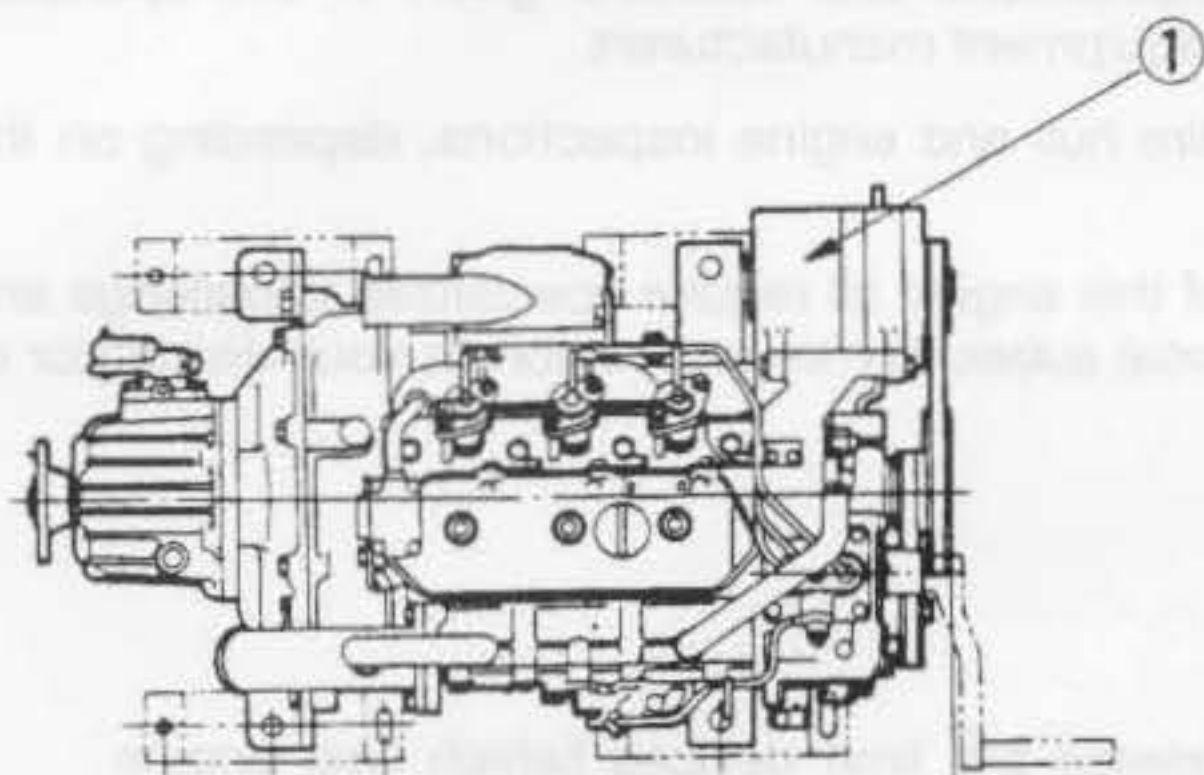

2GM20(C)(V), 3GM30(C)(V)

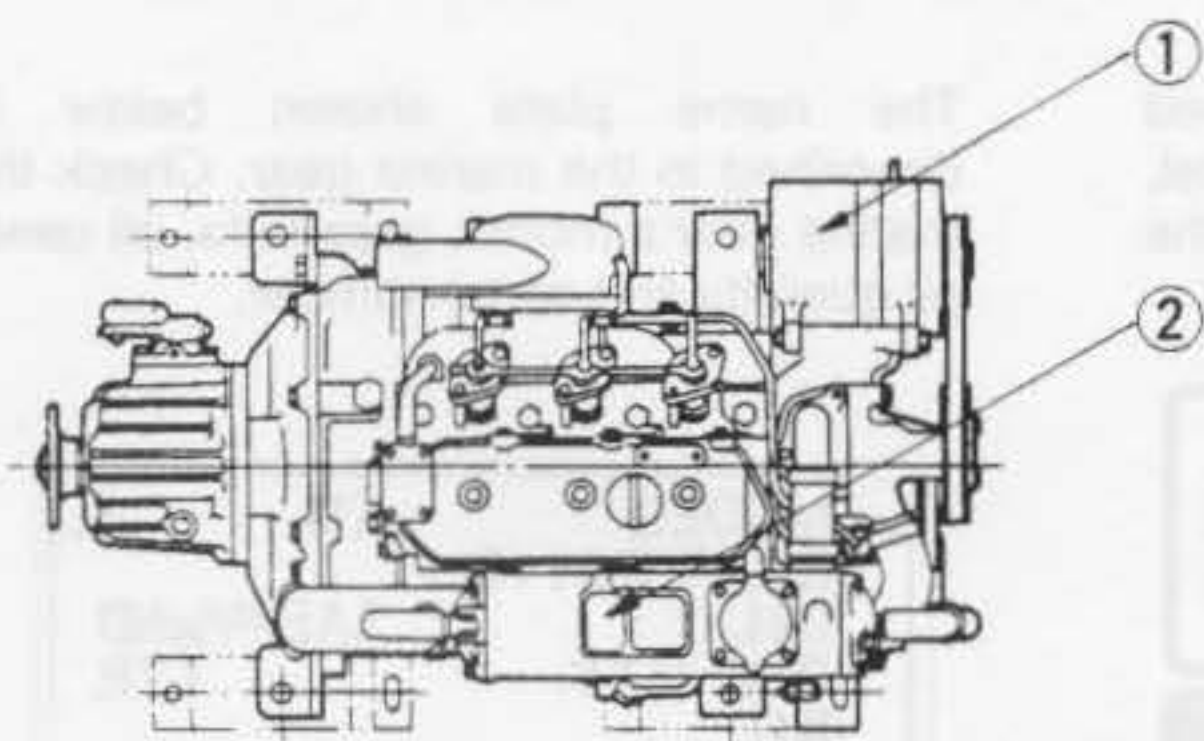

2GM20F(C)(V), 3GM30F(C)(V)

2. Product explanation

2.1 USE, DRIVING SYSTEM, ETC.

The engine is equipped with marine gear, connect the marine gear output shaft to the propeller shaft.

In order to obtain full performance from your engine, it is imperative that you check the size and structure of the hull and use a propeller of the appropriate size.

The engine must be installed correctly with safe cooling water and exhaust piping and electrical wiring. The PTO work should be easy to use for onboard equipment.

To handle the drive equipment, driven systems (including the propeller) and other onboard equipment, be sure to observe the instructions and cautions given in the operation manuals supplied by the shipyard and equipment manufacturers.

The laws of some countries may require hull and engine inspections, depending on the use, size and cruising area of the boat.

The installation, fitting and surveying of this engine all require specialized knowledge and engineering skills. Consult Yanmar's local subsidiary in your region or your distributor or dealer.

GB

⚠ WARNING

Never modify this product or release the limit devices (which limit engine speed, fuel injection quantity, etc.). Modification will impair the safety and performance of the product and functions and shorten the product life. Please note that any troubles arising from modification of the product will not be covered by our warranty.

DETAIL OF NAME PLATE

The name plate shown below is attached to the engine. Check the engine's model, output, rpm and serial number on the name plate.

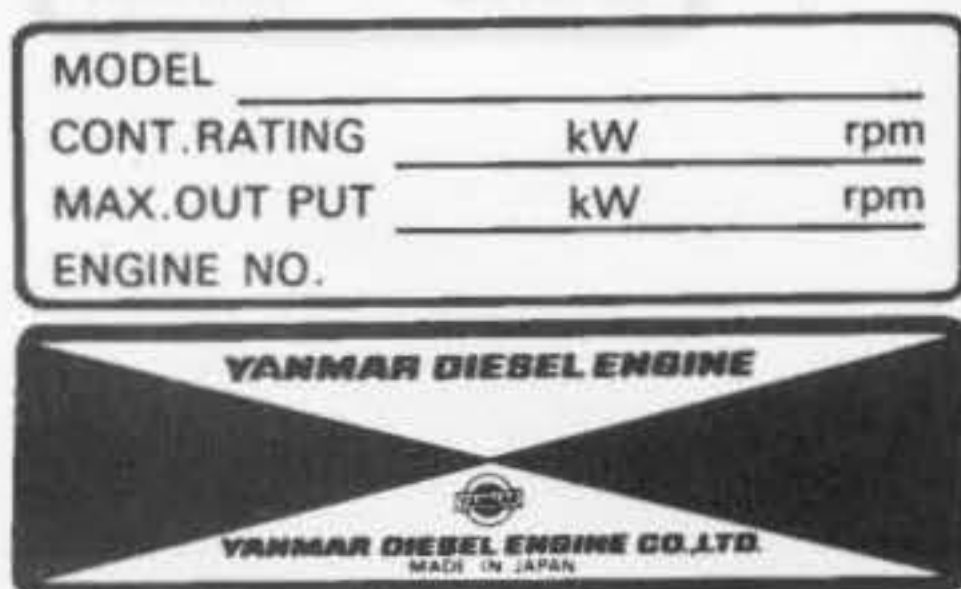

The name plate shown below is described in the marine gear. Check the marine gear's model, gear ratio, oil used, oil quantity and serial number.



2. Product explanation

2.2 Engine Specifications

2.2.1 Direct Seawater Cooling Type, GM series

Engine Model				2GM20			3GM30			
Type		Vertical 4-cycle water cooled diesel engine								
Combustion system		Swirl pre-combustion chamber								
Number of cylinders		2			3					
Bore × stroke		mm (in.)		75 × 72 (2.95 × 2.83)						
Displacement		ℓ (cu.in.)		0.636 (38.81)			0.954 (58.21)			
Continuous rating output	Output/crankshaft speed	kW/rpm (HP/rpm)		11.8/3400 (16.0/3400)			17.7/3400 (24.1/3400)			
	Brake mean effective pressure	kg/cm ² (lb./in. ²)		6.66 (94.71)						
	Piston speed	m/sec. (ft./sec.)		8.16 (26.77)						
One hour rating output	Output/crankshaft speed	kW/rpm (HP/rpm)		13.4/3600 (18.2/3600)			20.1/3600 (27.3/3600)			
	Brake mean effective pressure	kg/cm ² (lb./in. ²)		7.07 (100.54)						
	Piston speed	m/sec. (ft./sec.)		8.64 (28.35)						
Compression ratio		23.0								
Fuel injection timing (b.T.D.C.)		°		15±1			18±1			
Fuel injection pressure		kg/cm ² (lb./in. ²)		170±5 (2347 – 2489)						
Main power take off		at Flywheel side								
Front power take off		at Crankshaft V-pulley side								
Direction of rotation	Crankshaft	Counter-clockwise viewed from stern								
	Propeller shaft (Ahead)	Clockwise viewed from stern								
Cooling system		Direct seawater cooling (rubber impeller water pump)								
Lubrication system		Complete enclosed forced lubrication								
Starting system	Type	Electric and manual								
	Starting motor	DC 12V, 1.0kW								
	AC generator	12V, 55A								
Marine gear system	Model	KM2P			KM2P		KM3P			
	Type	Mechanical cone clutch with single stage for both ahead and astern								
	Reduction ratio	Forward		2.21	2.62	3.22	2.21	2.62	3.20	
		Reverse		3.06	3.06	3.06	3.06	3.06	3.16	
	Propeller speed	Forward	rpm	1540	1298	1055	1540	1298	1063	
		Reverse	rpm	1113	1113	1113	1113	1113	1076	
	Lubricating oil capacity		ℓ (cu.in.)		0.3 (18.31)			0.3 (18.31)		0.35(21.36)
Weight		kg (lb.)		10.3 (22.71)			10.3 (22.71)		11.5(25.36)	
Dimensions	Overall length		mm (in.)		645 (25.39)			735 (28.9)		740(29.13)
	Overall width		mm (in.)		455 (17.91)			455 (17.91)		455(17.91)
	Overall height		mm (in.)		495 (19.50)			495 (19.50)		495(19.50)
Lubricating oil capacity (rake angle 8°)	Total		ℓ (cu.in.)		2.0 (122.05)			2.6 (158.65)		2.6(158.65)
	Effective		ℓ (cu.in.)		1.3 (79.33)			1.6 (97.63)		1.6(97.63)
Engine weight with marine gear		kg (lb.)		106 (233)			129 (283.8)		130 (286)	

(Note) 1. Rating condition: ISO 3046-1. 2. 1hp=0.7355 kW.

2. Product explanation

2.2.2 Fresh Water Cooling Type, GMF series

Engine Model				2GM20F			3GM30F		
Type		Vertical 4-cycle water cooled diesel engine							
Combustion system		Swirl pre-combustion chamber							
Number of cylinders		2			3				
Bore x stroke		mm (in.)		75 x 72 (2.95 x 2.83)					
Displacement		/ (cu.in.)		0.636 (38.81)			0.954 (58.21)		
Continuous rating output	Output/crankshaft speed	kW/rpm (HP/rpm)		11.8/3400 (16.0/3400)			17.7/3400 (24.1/3400)		
	Brake mean effective pressure	kg/cm ² (lb./in. ²)		6.66 (94.71)					
	Piston speed	m/sec. (ft./sec.)		8.16 (26.77)					
One hour rating output	Output/crankshaft speed	kW/rpm (HP/rpm)		13.4/3600 (18.2/3600)			20.1/3600 (27.3/3600)		
	Brake mean effective pressure	kg/cm ² (lb./in. ²)		7.07 (100.54)					
	Piston speed	m/sec. (ft./sec.)		8.64 (28.35)					
Compression ratio		23.0							
Fuel injection timing (b.T.D.C.)		°		15±1			18±1		
Fuel injection pressure		kg/cm ² (lb./in. ²)		170±5 (2347 - 2489)					
Main power take off		at Flywheel side							
Front power take off		at Crankshaft V-pulley side							
Direction of rotation	Crankshaft	Counter-clockwise viewed from stern							
	Propeller shaft (Ahead)	Clockwise viewed from stern							
Cooling system		Fresh water cooling with heat exchanger							
Lubrication system		Complete enclosed forced lubrication							
Starting system	Type	Electric							
	Starting motor	DC 12V, 1.0kW							
	AC generator	12V, 55A							
Marine gear system	Model	KM2P			KM2P		KM3P		
	Type	Mechanical cone clutch with single stage for both ahead and astern							
	Reduction ratio	Forward	2.21	2.62	3.22	2.21	2.62	3.20	
		Reverse	3.06	3.06	3.06	3.06	3.06	3.16	
	Propeller speed	Forward rpm	1540	1298	1055	1540	1298	1063	
		Reverse rpm	1113	1113	1113	1113	1113	1076	
	Lubricating oil capacity	/ (cu.in.)	0.3 (18.31)			0.3 (18.31)		0.35(21.36)	
Weight	kg (lb.)	10.3 (22.71)			10.3 (22.71)		11.5(25.36)		
Dimensions	Overall length	mm (in.)		650 (25.59)			735 (28.93)		745(29.33)
	Overall width	mm (in.)		482 (19.00)			455 (17.91)		455(17.91)
	Overall height	mm (in.)		545 (21.46)			545 (21.45)		545(21.45)
Lubricating oil capacity (rake angle 8°)	Total	/ (cu.in.)		2.0 (122.05)			2.6 (158.65)		2.6(158.65)
	Effective	/ (cu.in.)		1.3 (79.33)			1.6 (97.63)		1.6(97.63)
Engine weight with marine gear		kg (lb.)		114 (251)			137 (301.4)		138(303.6)
Cooling water capacity (fresh water)	Fresh water tank	/ (cu.in.)		2.9(176.97)			3.4 (207.48)		
	Sub-tank	/ (cu.in.)		0.8 (48.82)					

(Note) 1. Rating condition: ISO 3046-1. 2. 1hp=0.7355 kW.

2. Product explanation

2.2.3 Direct Seawater Cooling Type, GMV series

Engine Model			2GM20V	3GM30V	
Type			Vertical 4-cycle water cooled diesel engine		
Combustion system			Swirl pre-combustion chamber		
Number of cylinders			2	3	
Bore x stroke		mm (in.)	75 x 72 (2.95 x 2.83)		
Displacement		ℓ (cu.in.)	0.636 (38.81)	0.954 (58.21)	
Continuous rating output	Output/crankshaft speed	kW/rpm (HP/rpm)	11.8/3400 (16.0/3400)	17.7/3400 (24.1/3400)	
	Brake mean effective pressure	kg/cm ² (lb./in. ²)	6.66 (94.71)		
	Piston speed	m/sec. (ft./sec.)	8.16 (26.77)		
One hour rating output	Output/crankshaft speed	kW/rpm (HP/rpm)	13.4/3600 (18.2/3600)	20.1/3600 (27.3/3600)	
	Brake mean effective pressure	kg/cm ² (lb./in. ²)	7.07 (100.54)		
	Piston speed	m/sec. (ft./sec.)	8.64 (28.35)		
Compression ratio			23.0		
Fuel injection timing (b.T.D.C.)		*	15±1	18±1	
Fuel injection pressure		kg/cm ² (lb./in. ²)	170±5 (2347 - 2489)		
Main power take off			at Flywheel side		
Front power take off			at Crankshaft V-pulley side		
Direction of rotation	Crankshaft		Clockwise viewed from stern		
	Propeller shaft (Ahead)		Clockwise viewed from stern		
Cooling system			Direct seawater cooling (rubber impeller water pump)		
Lubrication system			Complete enclosed forced lubrication		
Starting system	Type		Electric and manual		
	Starting motor		DC 12V, 1.0kW		
	AC generator		12V, 55A		
Marine gear system	Model		KM3V		
	Type		V-drive, mechanical cone clutch with single stage for both ahead and astern (Angle 15 °)		
	Reduction ratio	Forward		2.61	3.20
		Reverse		3.16	3.16
	Propeller speed	Forward	rpm	1303	1063
		Reverse	rpm	1076	1076
	Lubricating oil capacity	ℓ (cu.in.)	0,8 (48.92)		
Weight	kg (lb.)	19.5 (43.0)			
Dimensions	Overall length	mm (in.)	486 (19.13)	591,5 (23.29)	
	Overall width	mm (in.)	455 (17.91)	455 (17.91)	
	Overall height	mm (in.)	495 (19.49)	495 (19.49)	
Lubricating oil capacity (rake angle 8°)	Total	ℓ (cu.in.)	2.0 (122.05)	2.6 (158.65)	
	Effective	ℓ (cu.in.)	1.3 (79.33)	1.6 (97.63)	
Engine weight with marine gear		kg (lb.)	119 (261)	138 (303)	

(Note) 1. Rating condition: ISO 3046-1. 2. 1hp=0.7355 kW.

2. Product explanation

2.2.4 Fresh Water Cooling Type, GMFV series

Engine Model				2GM20FV	3GM30FV
Type		Vertical 4-cycle water cooled diesel engine			
Combustion system		Swirl pre-combustion chamber			
Number of cylinders		2		3	
Bore × stroke		mm (in.)	75 × 72 (2.95 × 2.83)		
Displacement		ℓ (cu.in.)	0.636 (38.81)		0.954 (58.21)
Continuous rating output	Output/crankshaft speed	kW/rpm (HP/rpm)	11.8/3400 (16.0/3400)		17.7/3400 (24.1/3400)
	Brake mean effective pressure	kg/cm ² (lb./in. ²)	6.66 (94.71)		
	Piston speed	m/sec. (ft./sec.)	8.16 (26.77)		
One hour rating output	Output/crankshaft speed	kW/rpm (HP/rpm)	13.4/3600 (18.2/3600)		20.1/3600 (27.3/3600)
	Brake mean effective pressure	kg/cm ² (lb./in. ²)	7.07 (100.54)		
	Piston speed	m/sec. (ft./sec.)	8.64 (28.35)		
Compression ratio		23.0			
Fuel injection timing (b.T.D.C.)		°	15±1		18±1
Fuel injection pressure		kg/cm ² (lb./in. ²)	170±5 (2347 – 2489)		
Main power take off		at Flywheel side			
Front power take off		at Crankshaft V-pulley side			
Direction of rotation	Crankshaft	Clockwise viewed from stern			
	Propeller shaft (Ahead)	Clockwise viewed from stern			
Cooling system		Fresh water cooling with heat exchanger			
Lubrication system		Complete enclosed forced lubrication			
Starting system	Type	Electric			
	Starting motor	DC 12V, 1.0kW			
	AC generator	12V, 55A			
Marine gear system	Model	KM3V			
	Type	V-drive, mechanical cone clutch with single stage for both ahead and astern (Angle 15 °)			
	Reduction ratio	Forward	2.36	2.61	3.20
		Reverse	3.16	3.16	3.16
	Propeller speed	Forward rpm	1441	1303	1063
Reverse rpm		1076	1076	1076	
Lubricating oil capacity		ℓ (cu.in.)	0.8 (48.92)		
Weight		kg (lb.)	19.5 (43.0)		
Dimensions	Overall length	mm (in.)	491 (19.33)		576 (22.68)
	Overall width	mm (in.)	482 (19.00)		455 (17.91)
	Overall height	mm (in.)	545 (21.46)		545 (21.46)
Lubricating oil capacity (rake angle 8°)	Total	ℓ (cu.in.)	2.0 (122.05)		2.6 (158.65)
	Effective	ℓ (cu.in.)	1.3 (79.33)		1.6 (97.63)
Engine weight with marine gear		kg (lb.)	125 (278)		147 (323)

(Note) 1. Rating condition: ISO 3046-1. 2. 1hp=0.7355 kW.

2. Product explanation

2.2.5 Direct Seawater Cooling Type, GMC series

Engine Model			2GM20C	3GM30C	
Type			Vertical 4-cycle water cooled diesel engine		
Combustion system			Swirl pre-combustion chamber		
Number of cylinders			2	3	
Bore x stroke		mm (in.)	75 x 72 (2.95 x 2.83)		
Displacement		ℓ (cu.in.)	0.636 (38.81)	0.954 (58.21)	
Continuous rating output	Output/crankshaft speed	kW/rpm (HP/rpm)	11.8/3400 (16.0/3400)	17.7/3400 (24.1/3400)	
	Brake mean effective pressure	kg/cm ² (lb./in. ²)	6.66 (94.71)		
	Piston speed	m/sec. (ft./sec.)	8.16 (26.77)		
One hour rating output	Output/crankshaft speed	kW/rpm (HP/rpm)	13.4/3600 (18.2/3600)	20.1/3600 (27.3/3600)	
	Brake mean effective pressure	kg/cm ² (lb./in. ²)	7.07 (100.54)		
	Piston speed	m/sec. (ft./sec.)	8.64 (28.35)		
Compression ratio			23.0		
Fuel injection timing (b.T.D.C.)		°	15±1	18±1	
Fuel injection pressure		kg/cm ² (lb./in. ²)	170±5 (2347 - 2489)		
Main power take off			at Flywheel side		
Front power take off			at Crankshaft V-pulley side		
Direction of rotation	Crankshaft		Counter-clockwise viewed from stern		
	Propeller shaft (Ahead)		Clockwise viewed from stern		
Cooling system			Direct seawater cooling (rubber impeller water pump)		
Lubrication system			Complete enclosed forced lubrication		
Starting system	Type		Electric and manual		
	Starting motor		DC 12V, 1.0kW		
	AC generator		12V, 55A		
Sail drive system	Model		SD20		
	Type		Sail drive unit- Dog type clutch, spiral bevel gear type		
	Reduction ratio	Forward		2.64	
		Reverse		2.64	
	Propeller speed	Forward rpm		1290	
Reverse rpm			1290		
Dimensions	Overall length	mm (in.)	503 (19.80)	591.5 (23.28)	
	Overall width	mm (in.)	455 (17.91)	455 (17.91)	
	Overall height	mm (in.)	495 (19.50)	495 (19.50)	
Lubricating oil capacity (rake angle 8°)	Total	ℓ (cu.in.)	2.0 (122.03)	2.6 (158.65)	
	Effective	ℓ (cu.in.)	1.3 (79.32)	1.6 (97.63)	
Engine weight with sail drive		kg (lb.)	134 (294.8)	153 (336.6)	

(Note) 1. Rating condition: ISO 3046-1. 2. 1hp=0.7355 kW.

(Note) Sail drive unit will be coupled with the engine in the market.

GB

2. Product explanation

2.2.6 Fresh Water Cooling Type, GMFC series

Engine Model			2GM20FC	3GM30FC	
Type			Vertical 4-cycle water cooled diesel engine		
Combustion system			Swirl pre-combustion chamber		
Number of cylinders			2	3	
Bore × stroke		mm (in.)	75 × 72 (2.95 × 2.83)		
Displacement		ℓ (cu.in.)	0.636 (38.81)	0.954 (58.21)	
Continuous rating output	Output/crankshaft speed	kW/rpm (HP/rpm)	11.8/3400 (16.0/3400)	17.7/3400 (24.1/3400)	
	Brake mean effective pressure	kg/cm ² (lb./in. ²)	6.66 (94.71)		
	Piston speed	m/sec. (ft./sec.)	8.16 (26.77)		
One hour rating output	Output/crankshaft speed	kW/rpm (HP/rpm)	13.4/3600 (18.2/3600)	20.1/3600 (27.3/3600)	
	Brake mean effective pressure	kg/cm ² (lb./in. ²)	7.07 (100.54)		
	Piston speed	m/sec. (ft./sec.)	8.64 (28.35)		
Compression ratio			23.0		
Fuel injection timing (b.T.D.C.)		"	15±1	18±1	
Fuel injection pressure		kg/cm ² (lb./in. ²)	170±5 (2347 – 2489)		
Main power take off			at Flywheel side		
Front power take off			at Crankshaft V-pulley side		
Direction of rotation	Crankshaft		Counter-clockwise viewed from stern		
	Propeller shaft (Ahead)		Clockwise viewed from stern		
Cooling system			Fresh water cooling with heat exchanger		
Lubrication system			Complete enclosed forced lubrication		
Starting system	Type		Electric		
	Starting motor		DC 12V, 1.0kW		
	AC generator		12V, 55A		
Sail drive system	Model		SD20		
	Type		Sail drive unit – Dog type clutch, spiral bevel gear type		
	Reduction ratio	Forward		2.64	
		Reverse		2.64	
	Propeller speed	Forward rpm		1290	
Reverse rpm			1290		
Dimensions	Overall length	mm (in.)	508 (20.00)	593 (23.34)	
	Overall width	mm (in.)	482 (18.97)	455 (17.91)	
	Overall height	mm (in.)	545 (21.45)	545 (21.45)	
Lubricating oil capacity (rake angle 8°)	Total	ℓ (cu.in.)	2.0 (122.03)	2.6 (158.65)	
	Effective	ℓ (cu.in.)	1.3 (79.32)	1.6 (97.63)	
Engine weight with sail drive		kg (lb.)	142 (312.4)	161 (354.2)	
Cooling water capacity (fresh water)	Fresh water tank	ℓ (cu.in.)	2.9(176.97)	3.4 (207.48)	
	Sub-tank	ℓ (cu.in.)	0.8 (48.82)		

(Note) 1. Rating condition: ISO 3046-1. 2. 1hp=0.7355 kW.

(Note) Sail drive unit will be coupled with the engine in the market.

2. Product explanation

2.3 Names of Parts

Non Operation Side

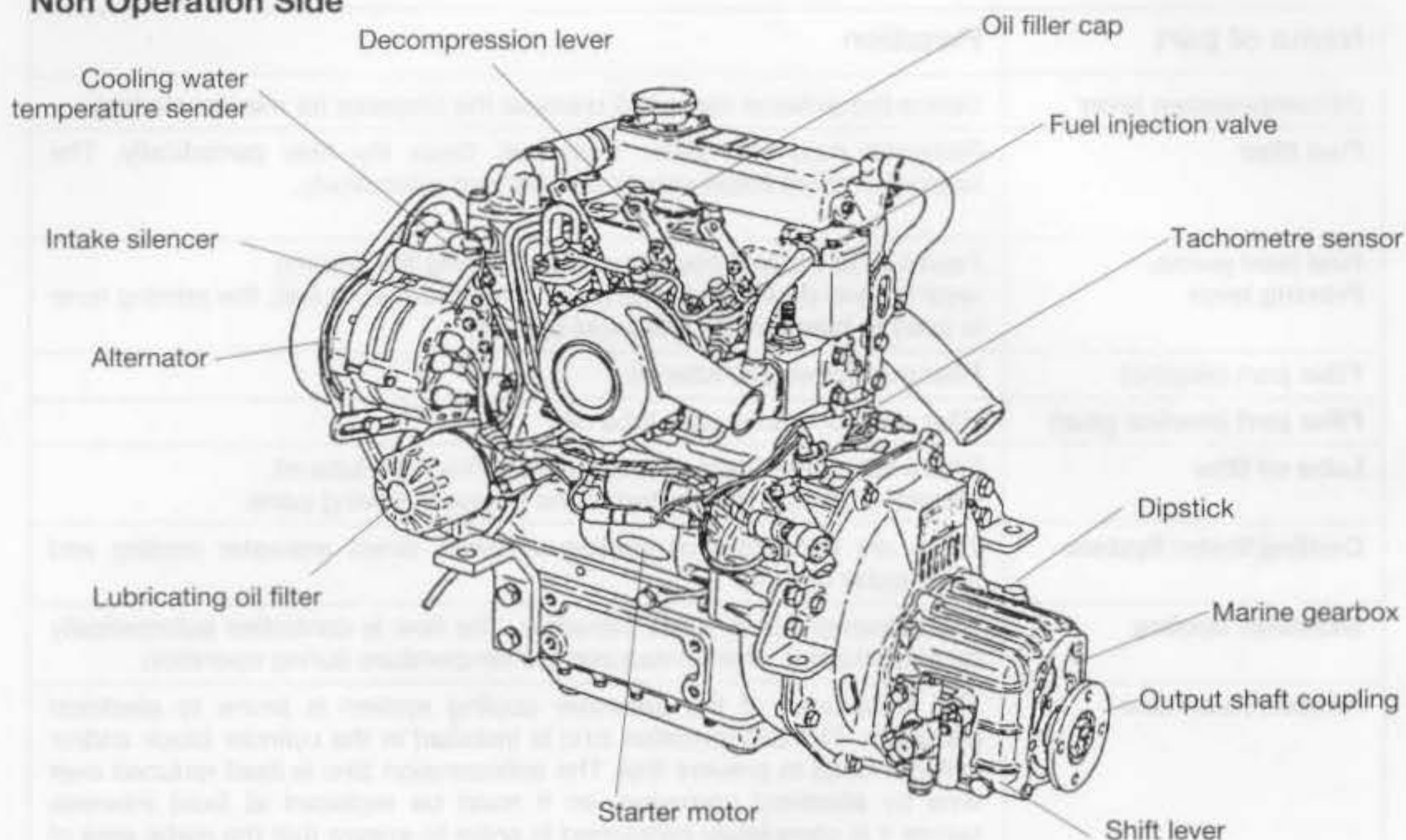

Air intake side of 3GM30F with KM3P

Operation Side

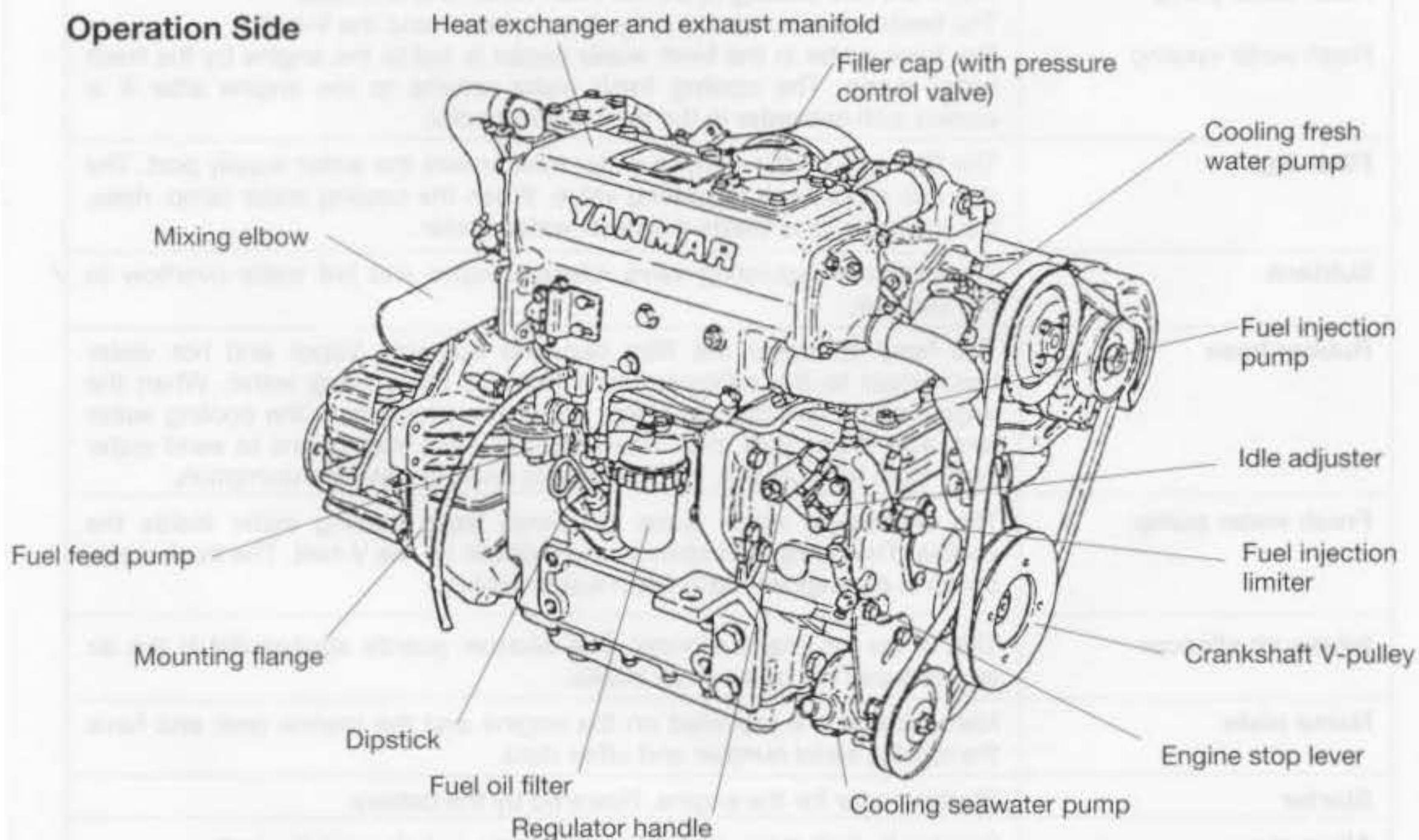

Exhaust side of 3GM30F with KM3P

2. Product explanation

2.4 Major Servicing Parts

Name of part	Function
Decompression lever	Opens the exhaust valve and releases the pressure for manual starting.
Fuel filter	Removes dust and water from fuel. Drain the filter periodically. The internal element (filter) should be changed periodically.
Fuel feed pump, Priming lever	Feed fuel to the fuel injection pump. Moving the priming lever up and down feeds the fuel. When there is no fuel, the priming lever is used to bleed air from the fuel system.
Filler port (engine)	Filler port for engine lube oil.
Filler port (marine gear)	Filler port for marine gear lube oil.
Lube oil filter	Filters fine metal fragments and carbon from the lube oil. Filtered lube oil is distributed to the engine's moving parts.
Cooling Water System	There are two types of cooling systems: direct seawater cooling and fresh water cooling.
Seawater cooling	The seawater pump feeds seawater. The flow is controlled automatically by a thermostat which measures the temperature during operation.
Anticorrosion zinc	The metal area of the seawater cooling system is prone to electrical corrosion. The anticorrosion zinc is installed in the cylinder block and/or cylinder head to prevent this. The anticorrosion zinc is itself reduced over time by electrical corrosion, so it must be replaced at fixed intervals before it is completely consumed in order to ensure that the metal area of the seawater cooling system remains fully protected.
Fresh water cooling <i>Fresh water pump</i> <i>Fresh water cooling</i>	There are two cooling systems: fresh water and seawater. The fresh water pump is run by the alternator and the V-belt. The fresh water in the fresh water cooler is fed to the engine by the fresh water pump. The cooling fresh water returns to the engine after it is cooled with seawater in the fresh water cooler.
Filler cap	The filler cap on the cooling water tank covers the water supply port. The cap has a pressure regulating valve. When the cooling water temp. rises, the pressure rises inside the fresh water cooler.
Subtank	The pressure regulating valve releases vapor and hot water overflow to the subtank.
Rubber hose	The hose connects the filler cap and subtank. Vapor and hot water discharged to the subtank return there to the cooling water. When the engine stops and cooling water cools, the pressure in the cooling water tank also drops very low. The filler cap valve then opens to send water back from the subtank. This minimizes cooling water consumption.
Fresh water pump	The centrifugal water pump circulates fresh cooling water inside the engine. The pump and alternator are driven by the V-belt. The fresh water pump is on engines using fresh water cooling.
Intake air silencer	This is the air intake silencer. The silencer guards against dirt in the air and reduces the noise of air intake.
Name plate	Name plates are provided on the engine and the marine gear and have the model, serial number and other data.
Starter	Starter motor for the engine. Powered by the battery.
Alternator	Rotates by belt drive, generates electricity and charges the battery.

2. Product explanation

2.5 Control Equipment

The equipment in the control room, making remote control possible, consists of: the instrument panel, which is connected by wire harness; the remote control handle, which is hooked up by remote control cable to each of the engine control levers, and the stopping equipment.

2.5.1 Control Panel

Electric Operation

There are two control panel options. The controls and alarm lamps included are shown below.

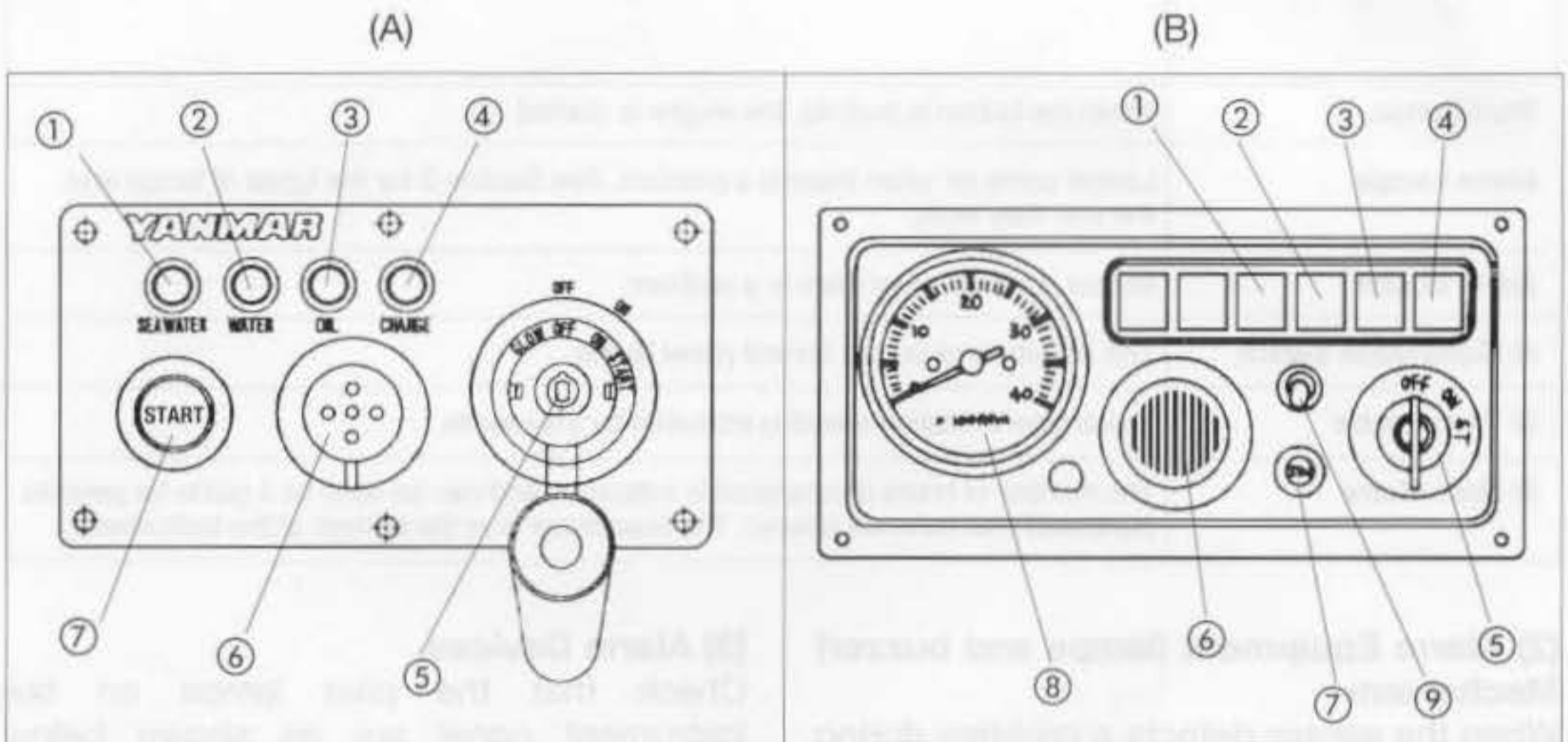

- ① Water Proof (sail drive)
- ② High temp. cooling water
- ③ Low lube oil pressure

- ④ Charge
- ⑤ Key switch
- ⑥ Buzzer

- ⑦ Start switch
- ⑧ Tachometre
- ⑨ Illumination switch

2. Product explanation

(1) Controls and Equipment

Note: The mark **Ⓑ** indicates equipment for type B control panel only.

Controls and Equipment	Mechanism
	<p>Key Switch Rotary switch with 2 positions. In the OFF position, the switch key can be inserted or removed. In OFF, all electric current is cut off. In ON (1 position to the right), the engine is turned on. In ON, electric current to the controls and equipment is turned on. The engine cannot be stopped with the key switch.</p>
Start Button	When the button is pushed, the engine is started.
Alarm Lamps	Lamps come on when there is a problem. See Section 2 for the types of lamps and the way they work.
Alarm Buzzer	Buzzer goes off when there is a problem.
Ⓑ Illumination Switch	This switch turns on the control panel lamps.
Ⓑ Tachometre	The engine's rotation speed is indicated by the needle.
Ⓑ Hour Metre	The number of hours of operation is indicated, and can be used as a guide for periodic (optional) maintenance checks. The hour meter is at the bottom of the tachometre.

(2) Alarm Equipment (lamps and buzzer) Mechanism

When the sensor detects a problem during operation, the lamps come on and the buzzer goes off.

Control Panel (Type A)

There are 4 separate alarm monitors on the upper left side of the control panel.

Control Panel (Type B)

Alarm monitors are located on the upper right side of the control panel. Under normal conditions, the monitors are off. When there is a problem, the monitors light up.

(3) Alarm Devices

Check that the pilot lamps on the instrument panel are as shown below when the starter key is turned on:

Pilot lamps	Low L.O. pressure alarm lamp	Lit
	Charge lamp	Lit
	Cooling water temp. alarm lamp	Off

NOTE:

All these signals will continue until the engine starts up or the key is turned off.

2. Product explanation

2.5.2 Single Lever Remote Control Handle (Morse Type) - Optional.

This remote control system uses a single handle to operate marine gear-clutch-(neutral, forward, reverse) and to control the engine speed.

NEUTRAL: Power to the propeller shaft is cut off and the engine idles.

FWD (FORWARD)

REV (REVERSE)

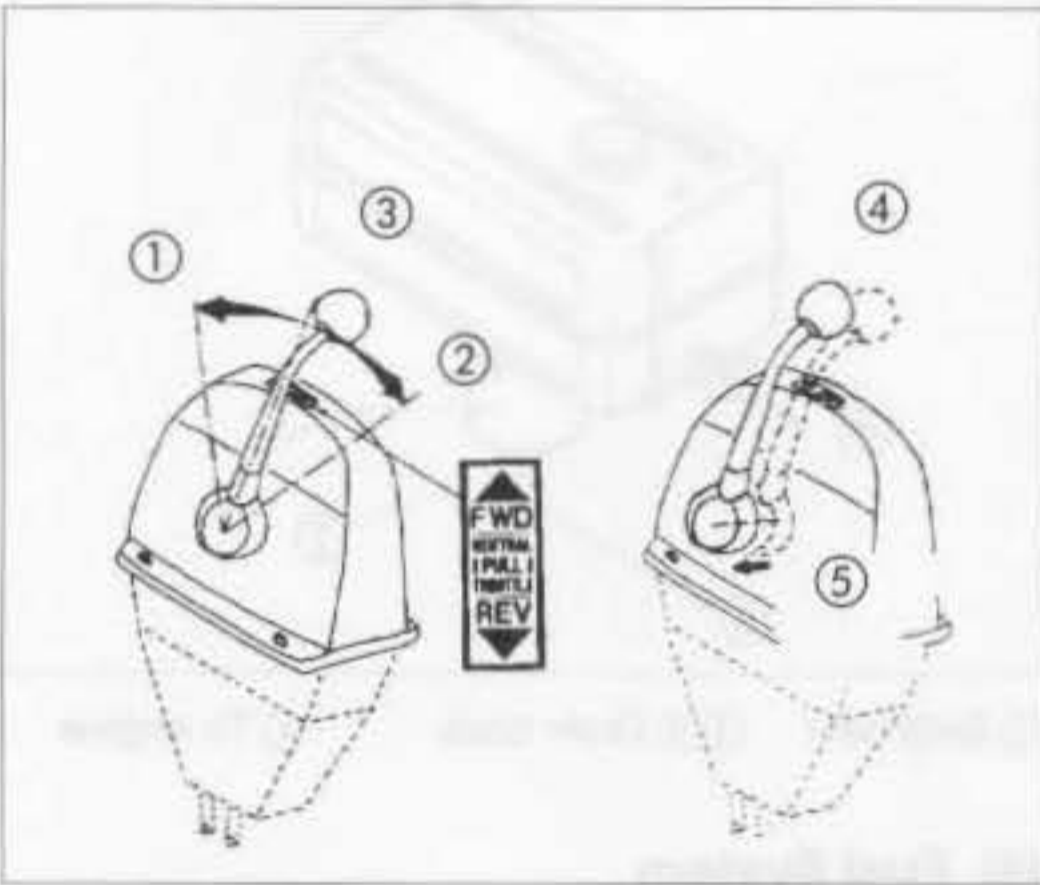

- ① FWD (forward)
- ② REV (reverse)
- ③ NEUTRAL (boat is stopped)
- ④ Clutch is disengaged
- ⑤ Pull out handle

The handle controls the course of the boat (ahead or astern) and, at the same time, acts as an accelerator increasing the engine speed as it is pushed further in the FWD or REV direction. If the handle is pulled out, engine speed can be controlled without engaging the clutch (clutch remains in the NEUTRAL, no load position).

2.5.3 Stopping Equipment

Manual Operation

The engine is stopped by pulling out the engine stop knob, which catches the fuel

injection pump stop lever thus cutting off fuel injection.

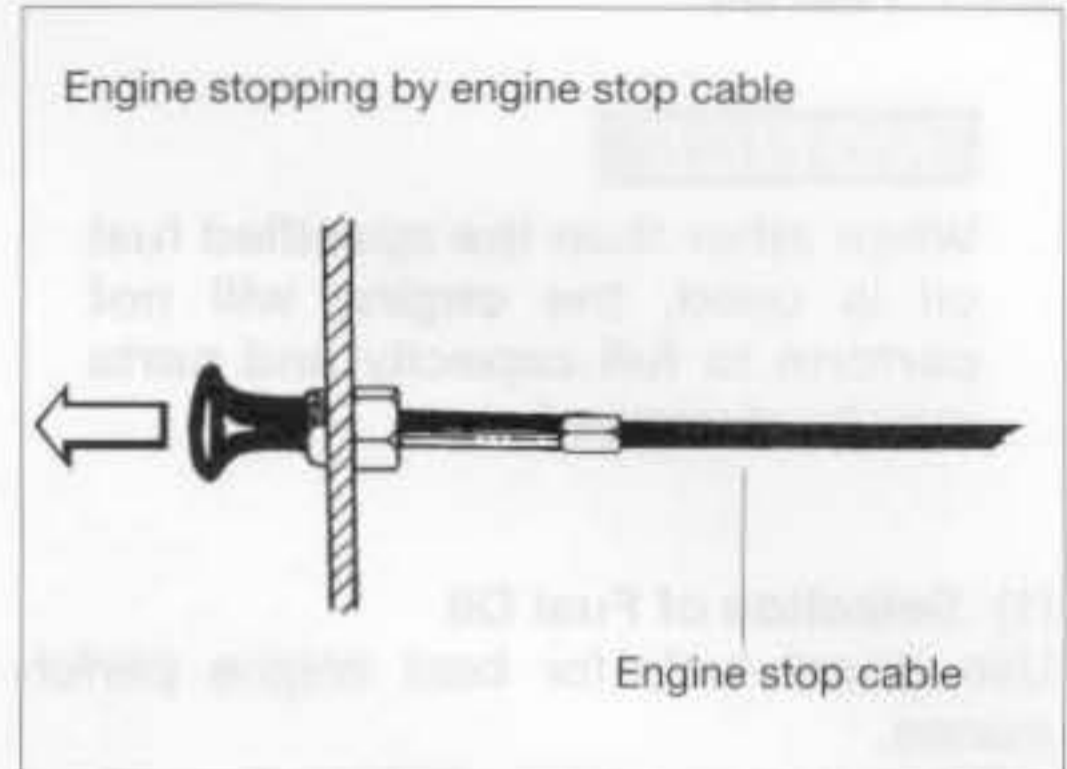

2.5.4 Decompression Equipment

When the decompression lever is pulled, the exhaust valve opens causing decompression inside the cylinders and making hand-turning possible. Returning the lever to the original position closes the exhaust valve, allowing compression and operation condition. For either manual or electric starting, when low rotation speed makes starting difficult, use the decompression lever to augment the rotation speed and enable starting.

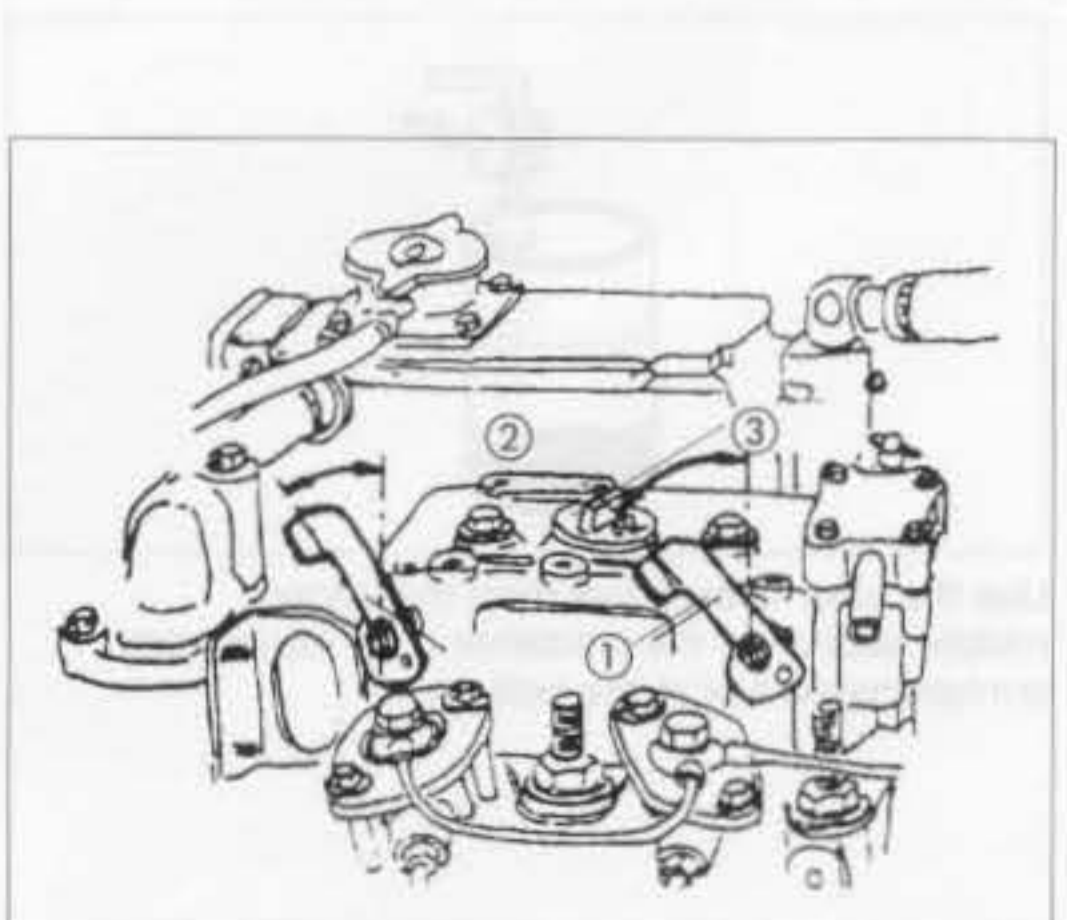

- ① Decomp. lever
- ② Drive
- ③ Decompression

GB

3. Operation

3.1 Fuel Oil, Lube Oil, and Cooling Water

3.1.1 Fuel Oil

NOTICE

When other than the specified fuel oil is used, the engine will not perform to full capacity and parts may be damaged.

(1) Selection of Fuel Oil

Use diesel fuels for best engine performance.

Cetane fuel number should be 45 or greater.

(2) Handling of Fuel Oil

1) Water and dust in the fuel cause engine failure. When fuel is stored, be sure that the inside of the storage container is clean, and that the fuel is stored away from dirt or rain water.

2) Keep the fuel container stationery for several hours to allow any dirt or water to settle to the bottom. Use a pump to extract the clear, filtered fuel from the top of the container for use.

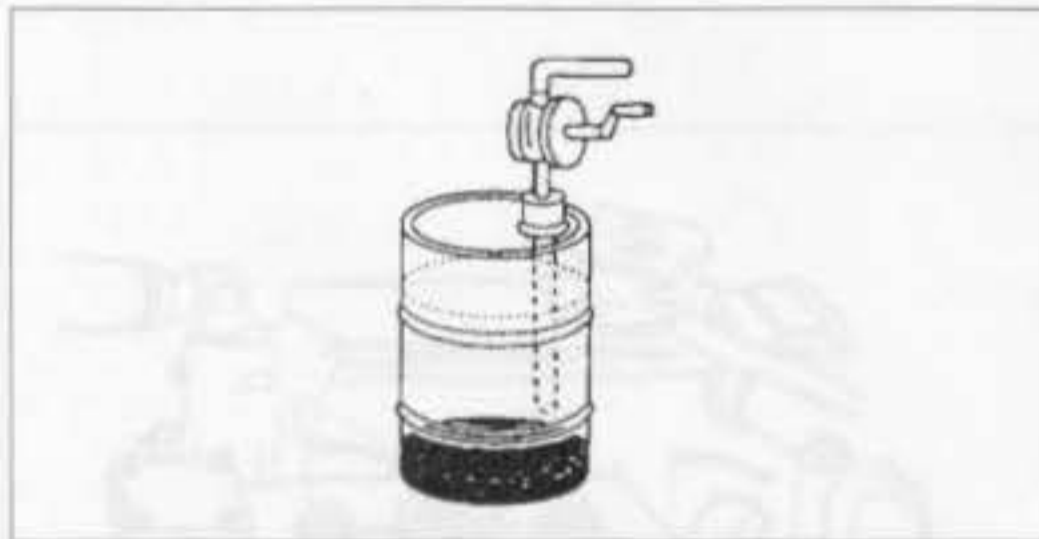

Use the clear filtered fuel from the upper middle section of the container only, leaving any contaminated fuel at the bottom.

(3) Fuel Tank (optional)

Be sure to attach a drain cock to the fuel tank to enable dirt and water to settle at the bottom of the tank to be drained off.

The fuel outlet should be positioned 20-30mm above the bottom of the tank so that only clean fuel is used.

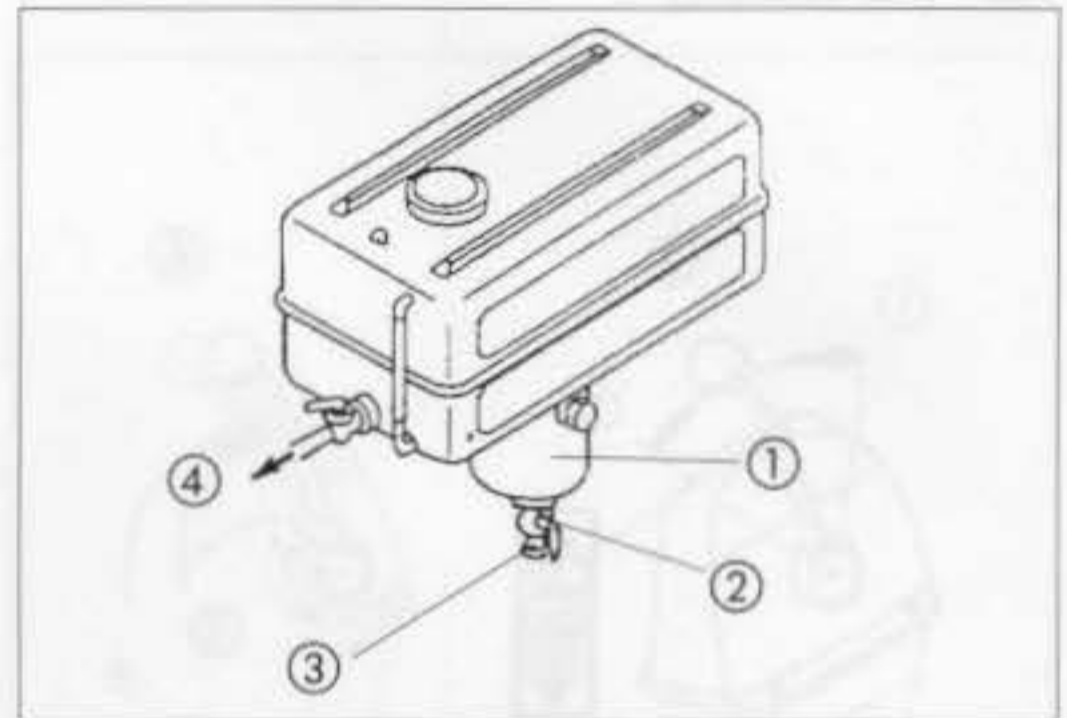

① Sediment ②③ Drain cock ④ To engine

(4) Fuel System

Install the fuel pipe from the fuel tank to the fuel pump in accordance with the diagram. The oil/water separator (optional) is placed at the centre section of the line.

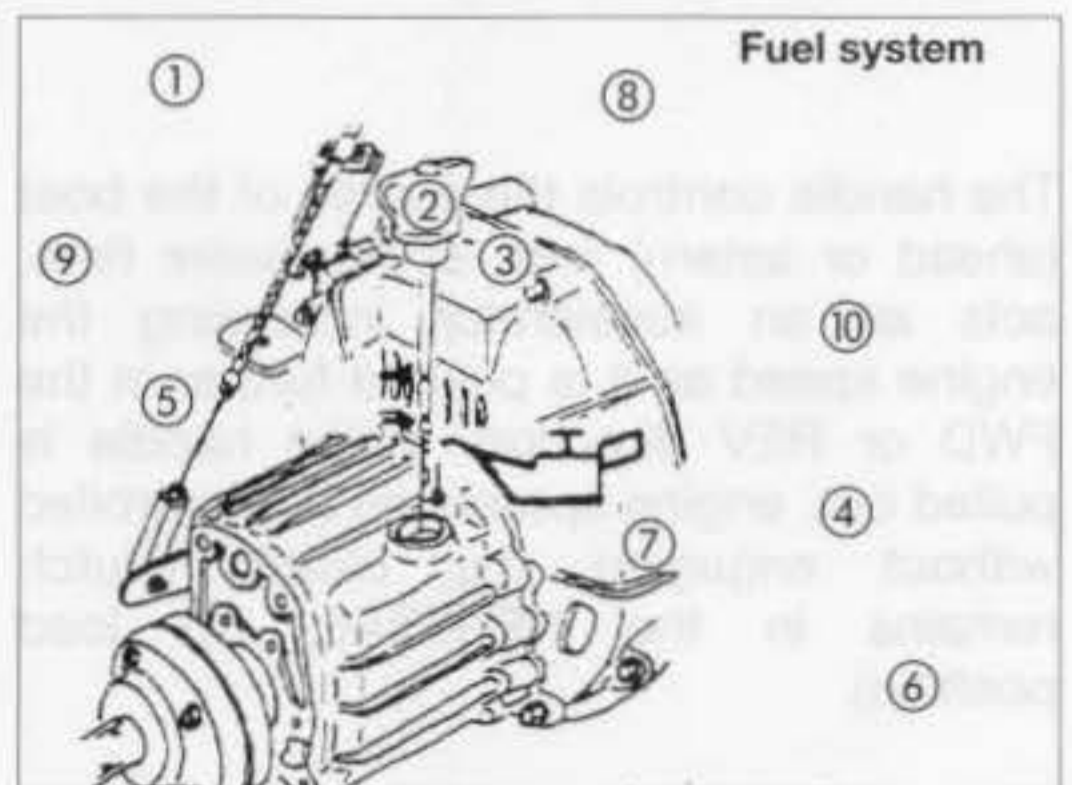

① Fuel filter ⑥ Drain cock
 ② Fuel feed pump (priming lever) ⑦ Fuel cock
 ③ Oil/Water separator ⑧ Fuel return
 ④ Approx. 25 mm ⑨ To fuel injection pump
 ⑤ Within 500 mm ⑩ Fuel tank

3. Operation

3.1.2 Lube Oil

NOTICE

Using other than the specified lube oil will lead to seizure of parts, abnormal wear, and shorten engine life.

(1) Selection of Engine Lube Oil

Use the following lube oil:

- API ClassificationCD
- SAE Viscosity15W40

(2) Selection of Oil for Marine Gear

- SAE Viscosity30

(3) The Sail Drive attached to 2GM20(F)(C) and 3GM30(F)(C)

- SAE Viscosity90 or 80W90

(4) Handling the Lube Oil

- 1) When handling and storing lube oil, be careful not to allow dust and water to enter the lube oil. Clean around the filter port before refilling.
- 2) Do not mix lube oils of different types or brands. Mixing may cause the chemical characteristics of the lube oil to change and lubricating performance to drop, reducing the engine's life. Before supplying lube oil to the engine and marine gear for the first time, extract all the lube oil already in the tank. Use new lube oil.
- 3) Lube oil supplied to the engine will undergo natural degeneration with time even when the engine is not used. Lube oil should be replaced at the specified intervals, regardless of whether the engine is being used or not.

Air temperature

Single grade Multi grade

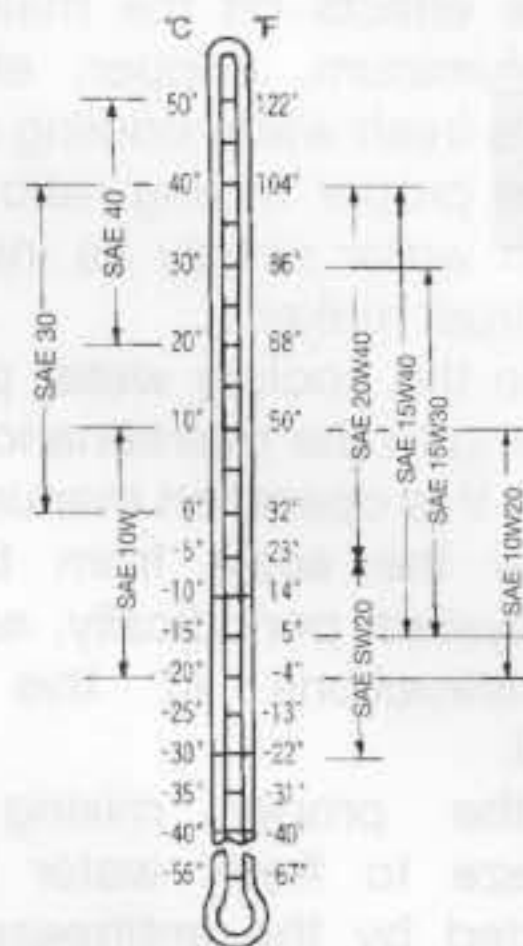

If you operate your equipment at temperatures below the limits shown, consult your dealer for special lubricants and starting aids.

3.1.3 Cooling Water (For Fresh Water Cooling Type only)

It is important to check the cooling water daily. Be sure to use clean soft water (tap water) for cooling fresh water.

NOTICE

Be sure to add antirust or anti-freeze to cooling fresh water.

In cold seasons, the antifreeze is especially important.

Without antirust, cooling performance will drop due to scale and rust in the cooling water system. Without antifreeze, cooling water will freeze and expand, breaking various parts.

For your reference, antifreeze mixed with antirust is now available in the market.

3. Operation

Handling of Cooling Water

1. Choose antirust which will not have any adverse effects on the materials (cast iron, aluminum, copper, etc.) of the engine's fresh water cooling system.
2. Use the proper mixing ratio of antirust to fresh water strictly as instructed by the antirust maker.
3. Replace the cooling water periodically, according to the maintenance schedule given in this operation manual.
4. Remove the scale from the cooling water system periodically, according to the instructions in this operation manual.
5. Use the proper mixing ratio of antifreeze to fresh water strictly, as instructed by the antifreeze maker. If too much antifreeze is used, the cooling performance of the cooling water will drop and the engine may become overheated.
6. Do not mix different brands of antirust or antifreeze.
Chemical reactions may make the antifreeze or antirust useless and engine trouble could result.

NOTICE

Excessive use of antifreeze also lowers the cooling efficiency of the engine. Be sure to use the mixing ratios specified by the antifreeze maker for your temperature range.

3.2 Before Initial Operation

Perform the following before using the engine for the first time:

3.2.1 Supply Fuel Oil

⚠ DANGER



Using gasoline, etc. may cause a fire.

To avoid mistakes, be sure to double-check the kind of fuel before inserting. Wipe off any spilled fuel carefully.

1. Before filling with fuel, wash out the fuel tank and fuel system with clean kerosene or light oil.
2. Fill the tank with clean fuel oil free of dirt and water.

3.2.2 Supply Engine Lube Oil

1. Remove the filler port cap (yellow) at the top of the bonnet, and fill with engine oil.
2. Fill with oil to the upper limit on the dipstick. Insert the dipstick fully to check the level.
3. Tighten the filler port cap securely by hand.

Engine Oil Capacity (Oil Pan)

2GM20(F)(V)(C)	Full:2.0 // Effective:1.3 /
3GM30(F)(V)(C)	Full:2.6 // Effective:1.6 /

NOTICE

Do not overfill. Overfilling will cause oil to be sprayed out from breather and lead to engine problems.

GB

3. Operation

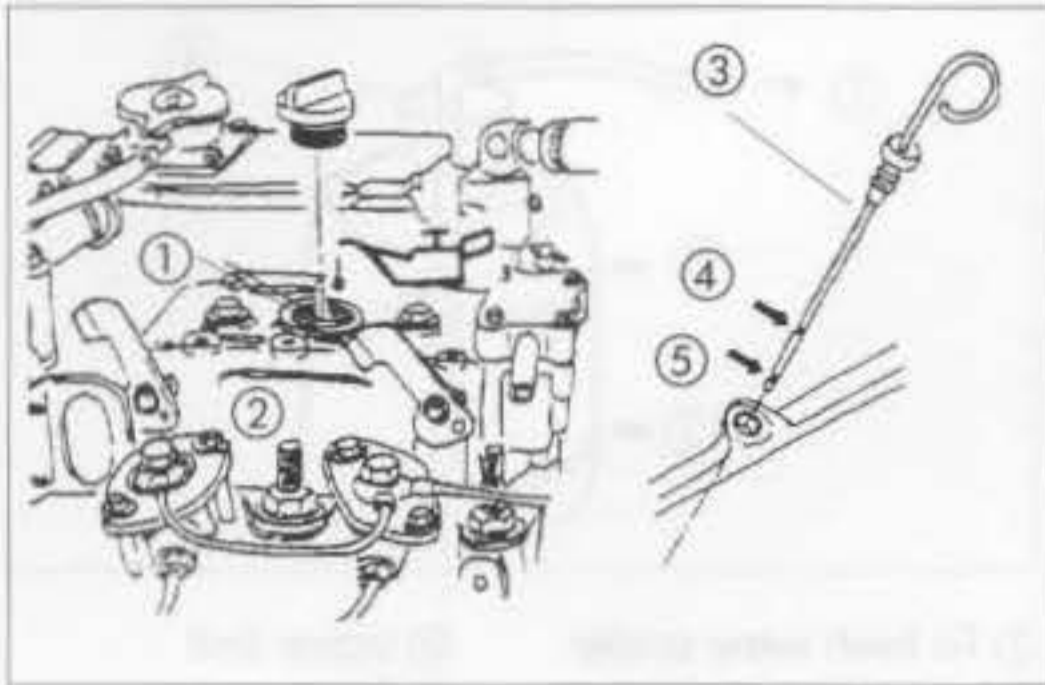

- ① Filler port
- ② Bonnet
- ③ Dipstick
- ④ Upper limit
- ⑤ Lower limit

3.2.3 Supply Clutch Lube Oil

1. Remove the filler port cap at the top of the bonnet, and fill with marine gear-clutch- lube oil.
2. Fill with oil to the upper limit on the dipstick. Insert the dipstick fully to check the level.
3. Tighten the filler port cap securely by hand.

Marine gear oil capacity

KM2P	0.3
KM3V	0.8
KM3P	0.35

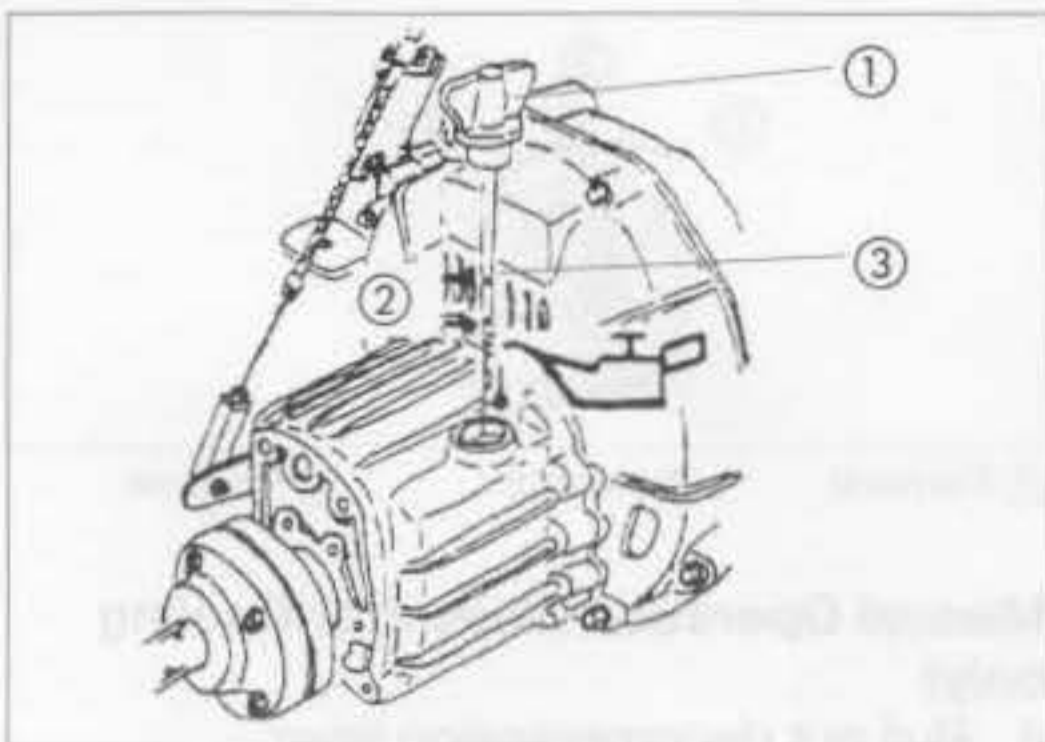

- ① Oil filler port cap
- ② Upper limit/Lower limit
- ③ Dipstick

3.2.4 Supply Cooling Water (For Fresh Water Cooling Type Only)

Supply cooling water according to the following procedures. Be sure to add antirust or antifreeze to the cooling water.

1. Be sure to close the 3 water drain cocks (See illustration right).

Note: The water drain cocks are opened before shipping from the plant.

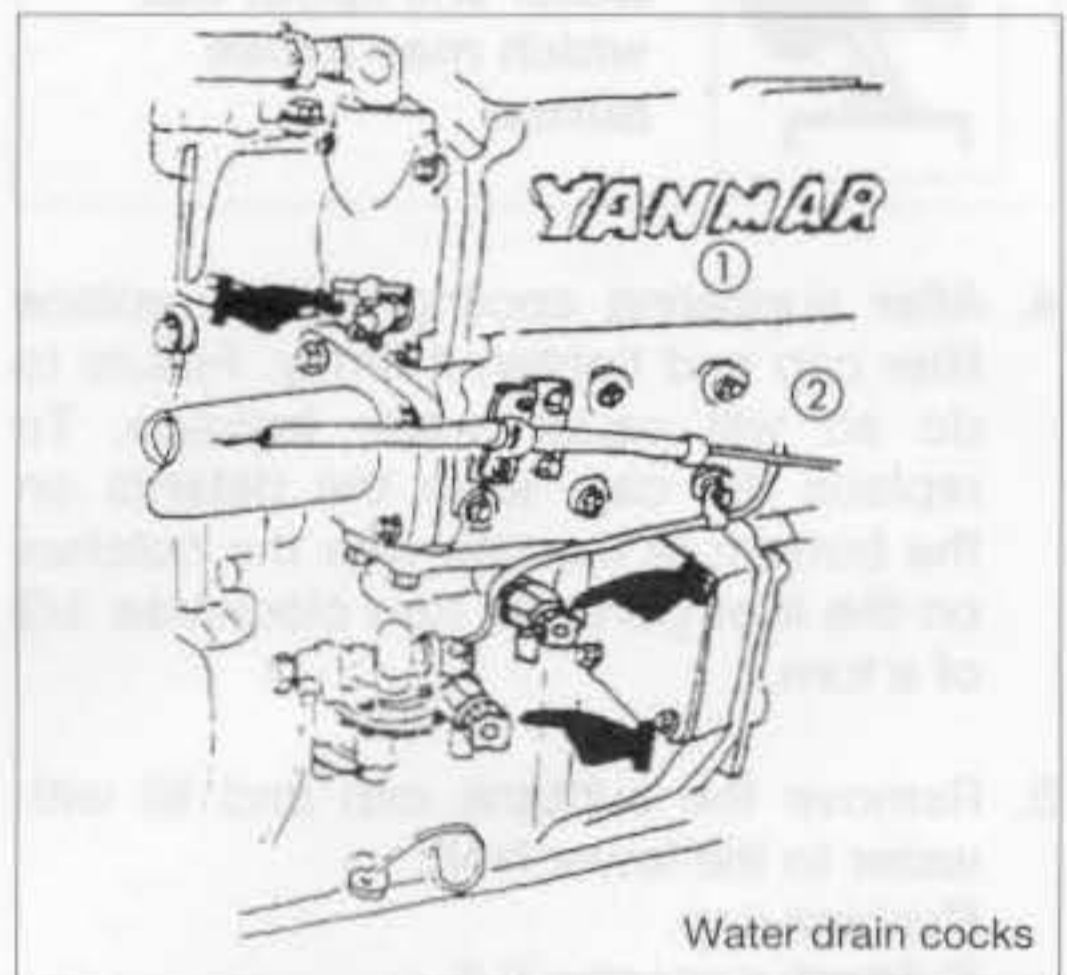

- ① Fresh water cooler
- ② Exhaust manifold

2. Remove the filler cap of the fresh water cooler by turning the cap counterclockwise 1/3 of a turn.

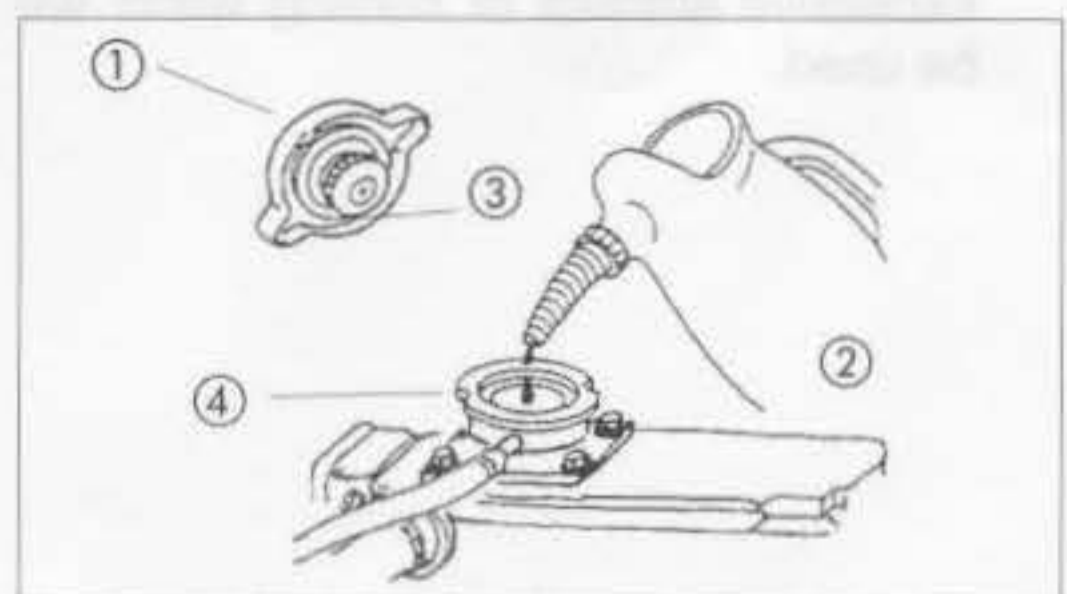

- ① Filler cap
- ② Fresh water cooler
- ③ Dents
- ④ Notches

3. Operation

3. Pour cooling water slowly into the fresh water tank so that air bubbles do not develop. Supply until the water overflows from the filler port.

Fresh water cooling capacity

2GM20F (V)(C)	2.9 /
3GM30F (V)(C)	3.4 /

⚠ DANGER



If the filler cap is loose, hot steam and water will spout out which may cause burns.

- GB**
4. After supplying cooling water, replace filler cap and tighten it firmly. Failure to do so will cause water leakage. To replace the cap, align the detents on the bottom of the cap with the notches on the filler port and turn clockwise 1/3 of a turn.
5. Remove the subtank cap and fill with water to the lower limit. Replace cap. Subtank capacity: 0.8 /
6. Check the rubber hose connecting the subtank to the fresh water cooler. Be sure the hose is securely connected and there is no looseness or damage. When the hose is not watertight, an excessive amount of cooling water will be used.

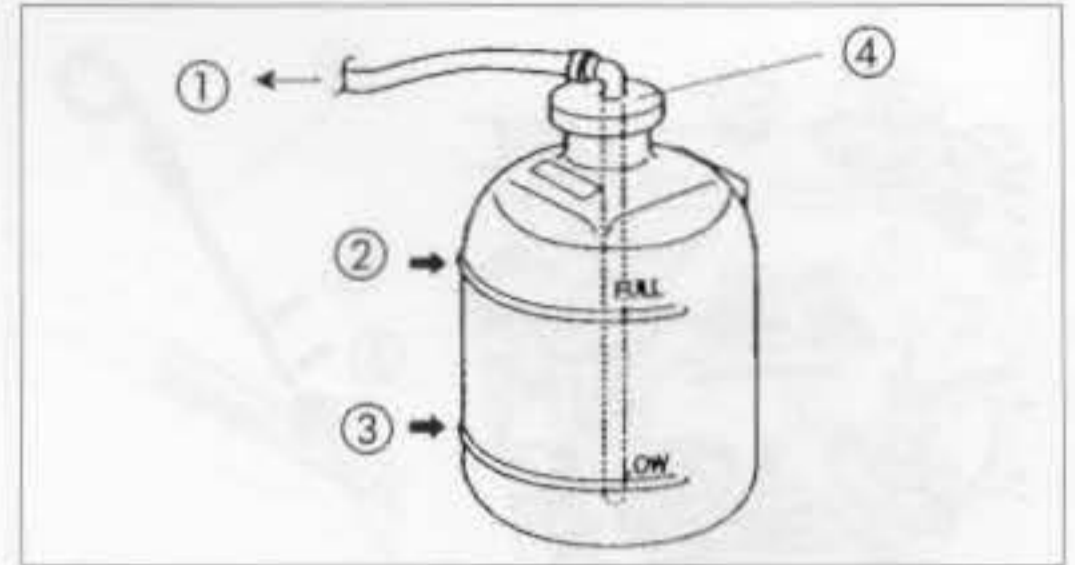

- ① To fresh water cooler ② Upper limit
③ Lower limit ④ Cap

3.2.5 Cranking

When the engine has not been used for a long period of time, lube oil will not be distributed to all of the operating parts. Using the engine in this condition will lead to seizure.

After a long period of disuse, distribute lube oil to each part by cranking. Perform in accordance with the following procedures before beginning operation.

1. Open Kingston cock.
2. Open fuel tank cock.
3. Put remote control lever in NEUTRAL.

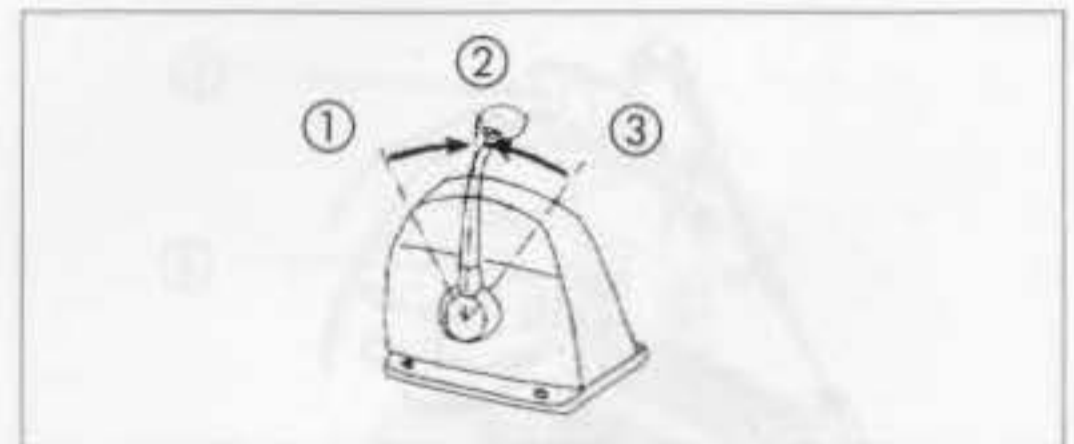

- ① Forward ② Neutral ③ Reverse

Manual Operation (Seawater Cooling only)

4. Pull out decompression lever.
5. Put starting handle on the starting shaft, and turn about 10 times. Check for abnormal noise while cranking.

3. Operation

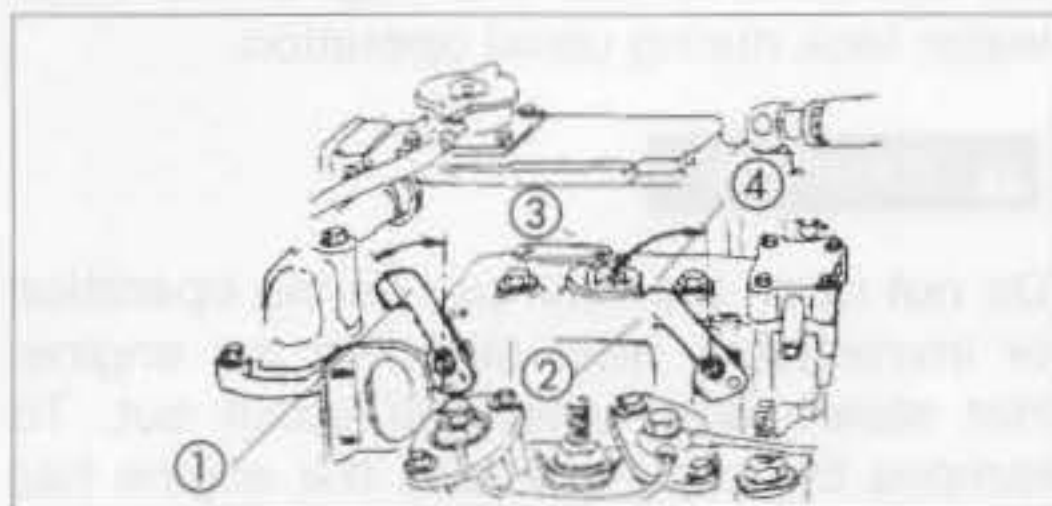

- ① Decomp. lever ③ Decomp. lever
② Drive ④ Compression

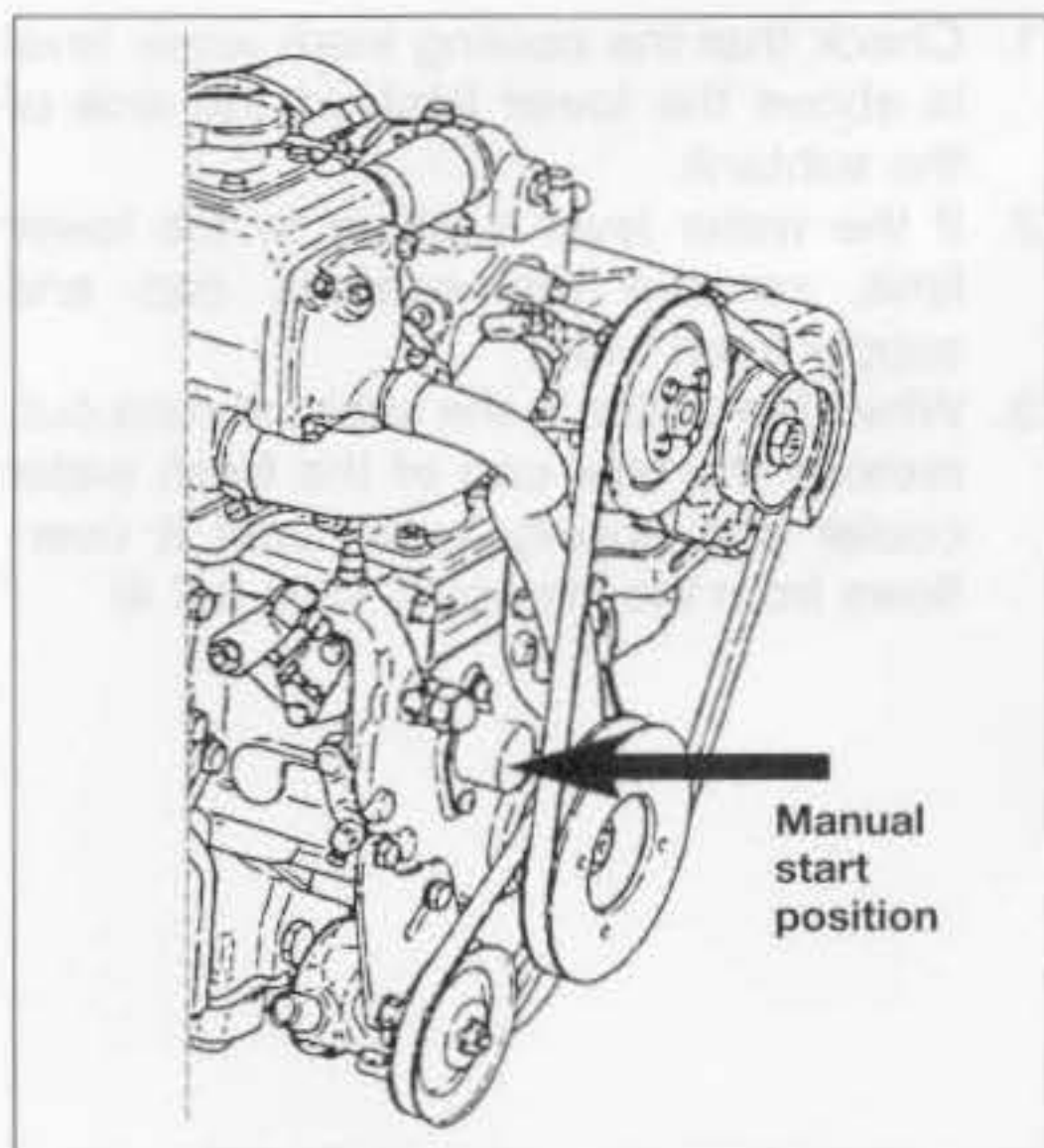

Electric Operation

4. Turn on battery switch and insert key into key switch. Turn the key to the ON position.
5. Pul the stop knob continuously while cranking.
6. When the start button is pushed, the engine will begin cranking. Continue cranking for about 5 seconds, and check for abnormal noise during that time. (If you remove your hand from the stop knob while cranking, the engine will start. Pull continuously.)

3.2.6 Check and Resupply Lube Oil and Cooling Water

When engine oil, clutch oil, or cooling water is supplied for the first time or when they must be replaced, conduct a trial operation of the engine for about 5 minutes and check the quantity of lube oil and cooling water. The trial engine operation will send the lube oil and cooling water to the parts, so the lube oil and cooling water levels will drop. Check and resupply as necessary.

1. Supplying engine lube oil (See 3.2.2)
2. Supplying marine gear lube oil (See 3.2.3)
3. Supplying cooling water (See 3.2.4)

3.3 Operating your engine

⚠ WARNING

To prevent exhaust gas poisoning, ensure good ventilation during operation. Install ventilation windows, ports or ventilators in the engine room.

Never touch or allow your clothes to touch the moving parts of the engine during operation. If the front drive shaft, V-belt, propeller shaft, etc. catches your body or clothes, serious injury may result. Check that no tools, cloth, etc. are left on or around the engine.

⚠ CAUTION

The engine is very hot during operation and immediately after stopping, especially the exhaust manifold and the exhaust pipe. Avoid burns! Never touch or allow your clothes to touch any part of the engine.

GB

3. Operation

3.3.1 Inspection Before Starting

Before starting the engine, make it a daily rule to conduct the following inspections:

(1) Visual Checks

Check for the following:

1. Lube oil leakage from the engine
2. Fuel oil leakage from the fuel system
3. Water leakage from the cooling water system
4. Damage to parts
5. Loosening or loss of bolts

If any problem is found, do not operate the engine before completing repairs.

(2) Checking and Resupplying Fuel Oil

Check the fuel level inside the fuel tank and supply with the recommended fuel, if necessary. (See 3.2.1)

(3) Checking and Resupplying Engine Lube Oil

1. Check the engine oil level with the oil dipstick.
2. If the oil level is low, supply with the recommended lube oil using the filler port. Supply oil up to the top mark on the oil dipstick. (See 3.2.2)

(4) Checking and Resupplying Clutch Lube Oil

1. Check the clutch oil level with the oil dipstick.
2. If the oil level is low, supply with the recommended lube oil using the filler port. Supply oil up to the top mark on the oil dipstick. (See 3.2.3)

(5) Checking and Resupplying Fresh Water (For Fresh Water Cooling System)

Check the fresh water level before operation while the engine is cold. Checking the water level while the engine is hot is dangerous, and the cooling water reading will be misleading due to thermal expansion.

Check and supply cooling water routinely at the subtank only.

Do not remove the filler cap of the fresh water tank during usual operation.

⚠ DANGER

Do not open the filler cap during operation or immediately after stopping the engine. Hot steam and water will spout out. To remove the cap, wait until the engine has cooled down, wrap the cap with a cloth and loosen the cap slowly. After checking, replace the cap and tighten firmly.

1. Check that the cooling fresh water level is above the lower limit on the side of the subtank.
2. If the water level is close to the lower limit, remove the subtank cap and supply fresh water.
3. When the water in the subtank runs out, remove the filler cap of the fresh water cooler and supply water until it overflows from the filler port. (See 3.2.4)



3. Operation

NOTICE

If the cooling fresh water runs out too often, or only the cooling fresh water in the fresh water tank drops without any change in the water level of the subtank, there may be some leakage of water or air. In such cases, consult your Yanmar dealer or distributor without delay.

Note: The water rises in the subtank during engine operation. This is not abnormal. After stopping the engine, the cooling water cools down and the extra water in the subtank returns to the fresh water tank.

(6) Checking the Remote Control Handle

Be sure to check that the remote control handle lever moves smoothly before use. If it is hard to operate, lubricate the joints of the remote control cable and also the lever bearings.

If the lever comes out or there is play in the lever, adjust the remote control cable. (See 4.3.4 (3))

(7) Checking the Alarm Devices Electric Operation

When operating the key switch, check that the alarm devices work normally. (See 2.5.1 (3))

(8) Preparing Fuel, Lube Oil, and Cooling Fresh Water in Reserve

Prepare sufficient fuel for the day's operation. Always store lube oil and cooling fresh water in reserve (for at least one refill) onboard, to be ready for emergencies.

3.3.2 How to Start the Engine

(1) Start the engine according to the following procedures:

Electric Operation

1. Open the Kingston cock.
2. Open the fuel tank cock.
3. Set the remote control lever in NEUTRAL.

NOTICE

Safety equipment (optional) makes it impossible to start the engine in any other position than NEUTRAL.

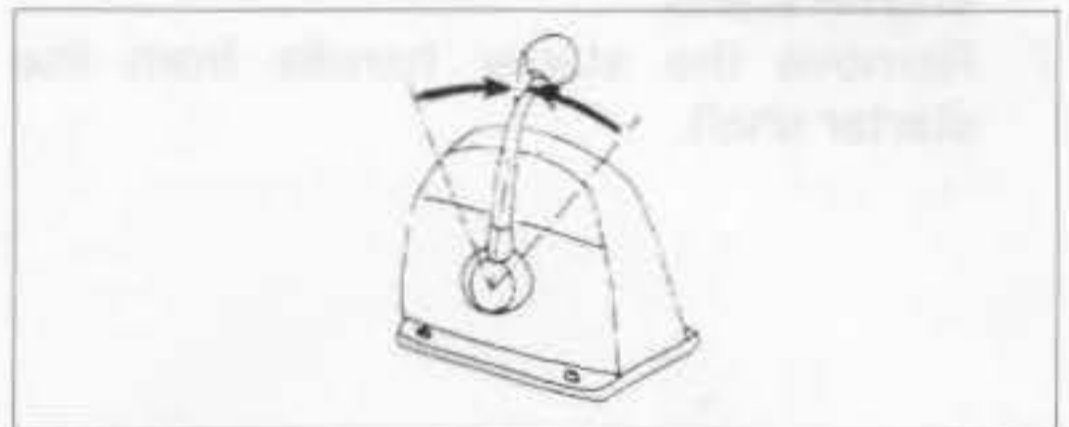

4. Turn on the battery switch.
5. Insert the key into the key switch and turn the key to ON. If the alarm buzzer sounds and alarm lamps come on, the alarm devices are normal.

Note: The cooling water temp. warning lamp does not come on. (See 2.5.1.(3))

6. Push the start button to start the engine. Release the start button when the engine has started. The alarm buzzer should stop and the alarm lamps go out.

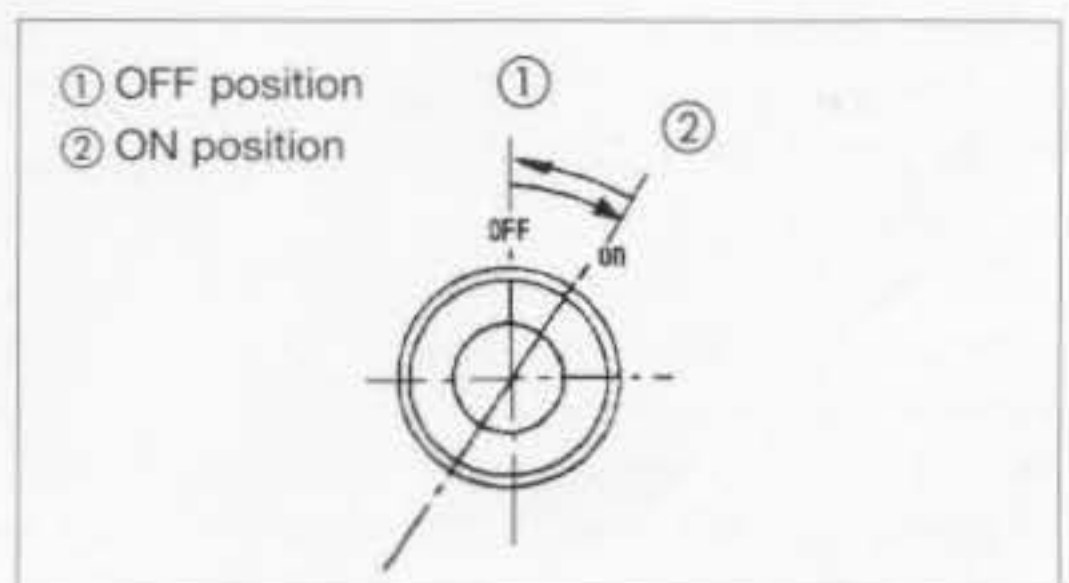

GB

3. Operation

Manual Operation (Seawater Cooling Only)

1. Open the Kingston cock.
2. Open the fuel tank cock.
3. Set the remote control lever in NEUTRAL.
4. Pull out the decompression lever.
5. Put the starter handle on the starter shaft, align the groove and pin, and turn by hand. When you begin turning, you will hear the sound of fuel being injected.
6. Turn the handle vigorously. When the rotation is rapid, return the decompression lever to original position. The engine starts.
7. Remove the starter handle from the starter shaft.

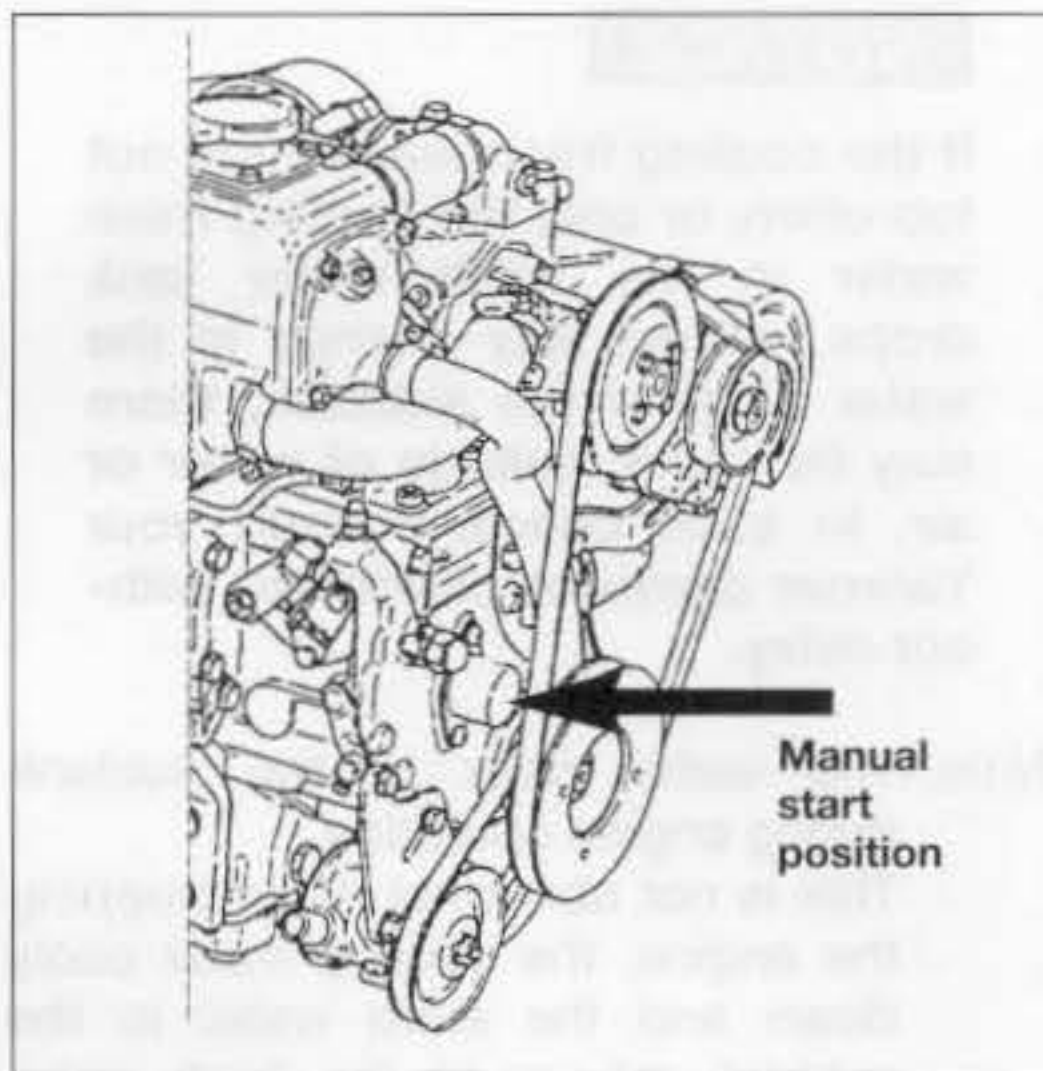

(2) Restarting After Starting Failure

Before pushing the start button again, be sure to confirm that the engine has stopped completely. If the engine is restarted while the engine still has not stopped, the pinion gear of the starter motor will be damaged.

Electric Operation

NOTICE

Do not hold the start button on for more than 15 seconds at a time. If the engine does not start the first time, wait for about 15 seconds before trying again. After the engine has started, do not turn the key off. (It should remain ON.) Alarm devices will not work when the key is OFF.

(3) Air Venting of the Fuel System After Starting Failure

If the engine only idles and won't start after several attempts, there may be air in the fuel system. If air is in the fuel system, fuel cannot reach the fuel injection pump. Vent the air in the system according to the following procedures.

GB

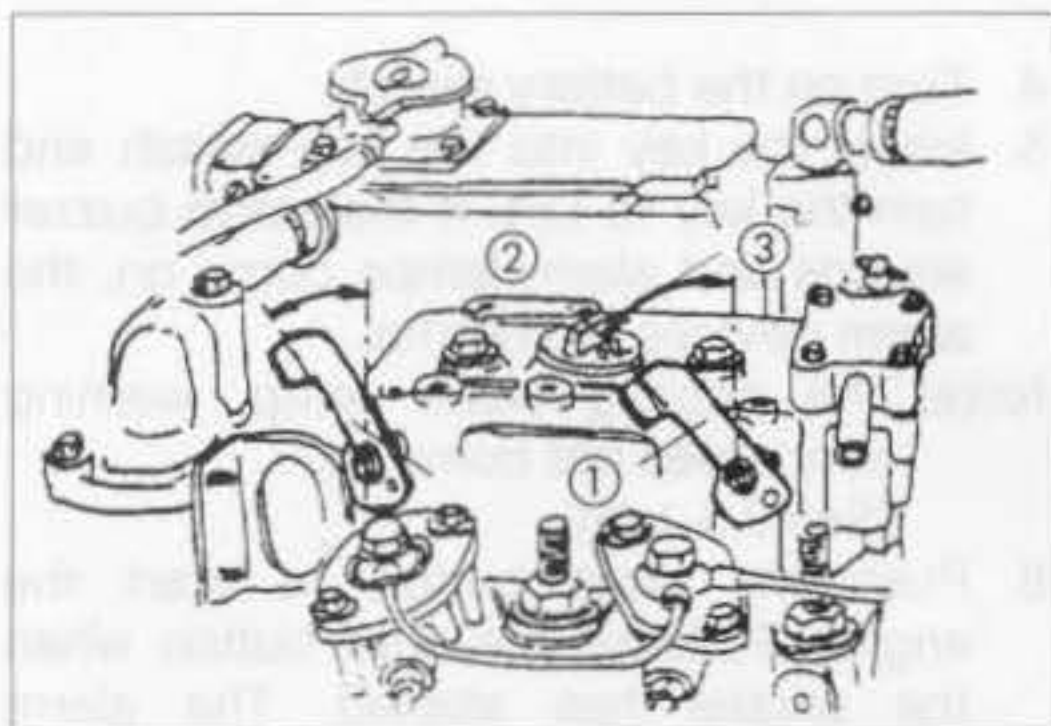

① Decomp. lever ② Drive ③ Decompression

3. Operation

Fuel System Air Venting Procedures

1. Check the fuel level in the fuel tank. Replenish if insufficient.
2. Loosen the air vent bolt at the top of the oil/water separator by turning it 2 or 3 times. When fuel which does not contain air bubbles comes out of the bolt hole, tighten the air vent bolt.
3. Loosen the air vent bolts of the fuel filter and the fuel injection pump by turning them 2 or 3 times.
4. Feed fuel with the fuel feed pump by moving the lever on the left side of the feed pump up and down.
5. Allow the fuel containing air bubbles to flow out from the air vent bolt holes. When the fuel coming out no longer contains bubbles, tighten the air vent bolts.

This completes the air venting of the fuel system. Try starting the engine again.

(4) After the Engine has Started

After the engine has started, check the following items at a low engine speed:

1. Check that the gauges and alarm devices on the instrument panel are normal.
2. Check for water or oil leakage from the engine.
3. Check that exhaust colour, engine vibrations and sound are normal.
4. When there are no problems, keep the engine at low speed with the boat still stopped to send lube oil to all parts of the engine.
5. Check that sufficient cooling water is discharged from the seawater outlet pipe. Operation with too small seawater discharge will burn the impeller of the seawater pump. If seawater discharge is too small, stop the engine immediately. Identify the cause and repair.

- Is the Kingston cock open?
- Is the inlet of the Kingston cock on the hull bottom clogged?
- Is the seawater suction hose broken, or does the hose suck in air due to a loose joint?

NOTICE

The engine will seize if it is operated when cooling seawater discharge is too small or if load is applied without any warming up operation.

3.3.3 Operation

(1) Engine Acceleration and Deceleration

Use the governor handle to control acceleration and deceleration. Move the handle slowly.

(2) FORWARD-NEUTRAL (boat stopped) – REVERSE Clutch

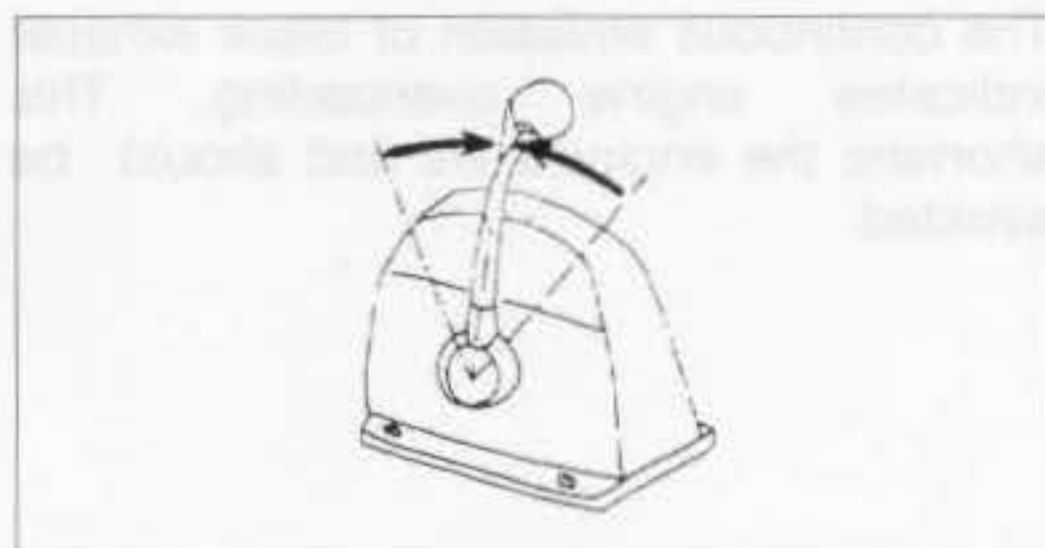

GB

3. Operation

Use the clutch handle to change from FORWARD to NEUTRAL (boat stopped) to REVERSE.

NOTICE

Shifting the clutch while operating at high speed or not pushing the handle fully into position (half clutch) will result in damage to clutch parts and abnormal wear.

1. Before using the clutch, be sure to move the governor handle to a low speed position (1000 rpm or less). Move the governor handle to a high speed position after completing clutch operation.
2. When changing between FORWARD and REVERSE, bring the clutch to NEUTRAL and pause before slowly shifting to the desired position. Do not shift abruptly from FORWARD to REVERSE or vice versa.
3. Move the clutch handle accurately and fully into the FORWARD, NEUTRAL, and REVERSE positions.

3.3.4 Cautions During Operation

Always be on the lookout for problems during engine operation.

Pay particular attention to the following:

(1) Is sufficient water being discharged from the seawater outlet pipe?

If the discharge is small, stop the engine immediately, identify the cause and repair.

(2) Is the exhaust colour normal?

The continuous emission of black exhaust indicates engine overloading. This shortens the engine's life and should be avoided.

(3) Are there abnormal vibrations or noise?

Do not operate at speeds which produce violent vibrations. Depending on the hull structure, engine and hull resonance may suddenly become great at a certain engine speed range, causing heavy vibrations. Avoid operation in this speed range. If you hear any abnormal sounds, stop the engine and inspect.

Electric Operation

(4) Alarm buzzer sounds during operation.

If the alarm buzzer sounds during operation, lower the engine speed immediately, check the warning lamps, and stop the engine for repairs.

(5) Is there water, oil, or gas leakage, or are there any loose bolts?

Check the engine room periodically for any problems.

(6) Is there sufficient fuel oil in the fuel oil tank?

Replenish fuel oil in advance to avoid running out of fuel during operation.

(7) When operating the engine at low speed for long periods of time, race the engine once every 2 hours.

Note: Racing the Engine

With the clutch in NEUTRAL, accelerate from the low speed position to the high speed position and repeat this process about 5 times. This is done to clean out carbon from the cylinders and the fuel injection valve.

Neglecting to race the engine will result in poor exhaust colour and reduce engine performance.

3. Operation

NOTICE

Electric Operation

Never turn off the battery switch or spark the battery cable during operation. Damage to parts in the electric system will result.

3.3.5 Stopping the Engine

Stop the engine in accordance with the following procedures:

1. Put the remote control handle in NEUTRAL.
2. Be sure to race the engine before stopping it. (See 3.3.4 (7))
3. Cool down the engine at low speed (approximately 1000 rpm) for about 5 minutes.

NOTICE

Stopping the engine suddenly while operating at high speed will cause the engine temperature to rise quickly, causing deterioration of the oil and sticking of parts.

Engine stopping by engine stop cable

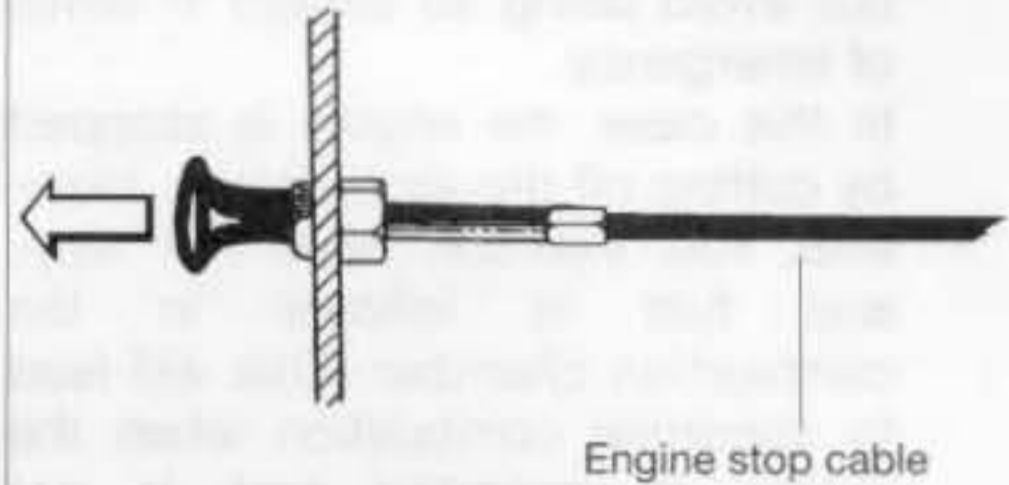

4. Continue to pull out the engine stop knob (stop lever) until the engine is completely stopped. If you release the knob before the engine has completely stopped, it may restart.

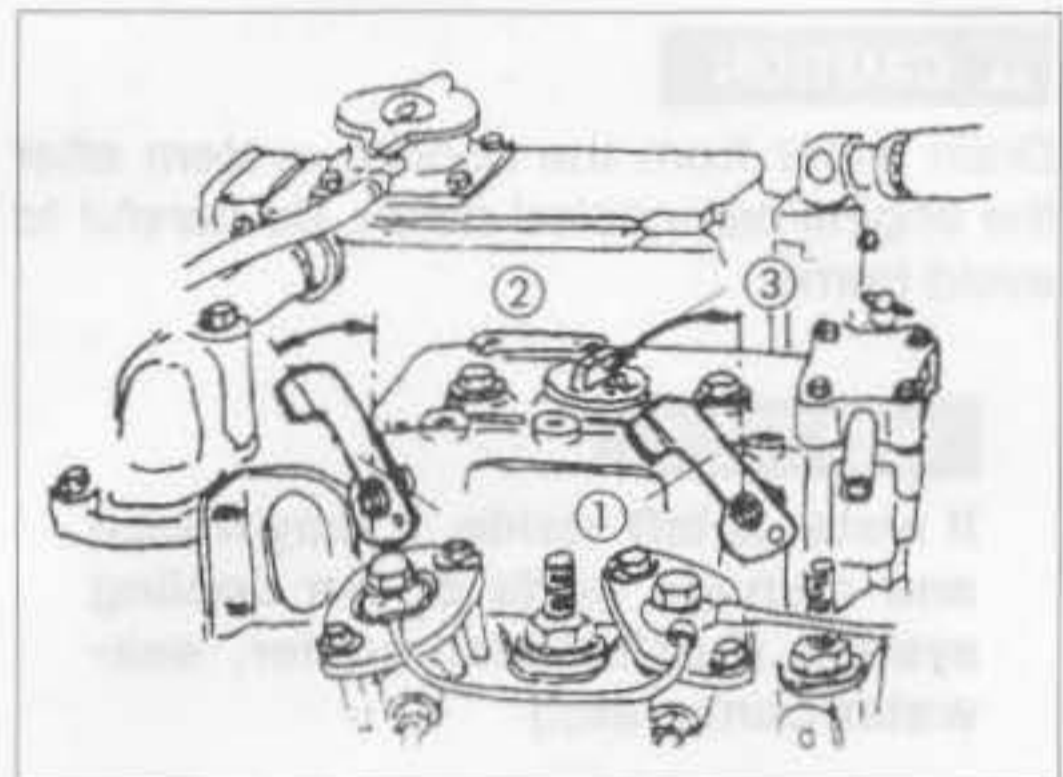

① Decomp. lever ② Drive ③ Decompression

5. Close the fuel tank cock.
6. Close the Kingston cock.

NOTICE

Neglecting to close the Kingston cock will allow water to leak into the boat and may cause it to sink. Be sure to close the cock.

GB

3. Operation

Note: The engine may be stopped by pulling out the decompression lever, but avoid doing so except in times of emergency.

In this case, the engine is stopped by cutting off the air pressure. However, fuel injection does not stop, and fuel is leftover in the combustion chamber. This will lead to abnormal combustion when the engine is restarted and is not desirable.

3.4 Long Term Storage

(1) In cold temperatures or before long term storage, be sure to drain the water from the seawater cooling system.

GB

⚠ CAUTION

Drain water from the cooling system after the engine has cooled down. Be careful to avoid burns.

NOTICE

If water is left inside, it may freeze and damage parts of the cooling system (fresh water cooler, seawater pump, etc.)

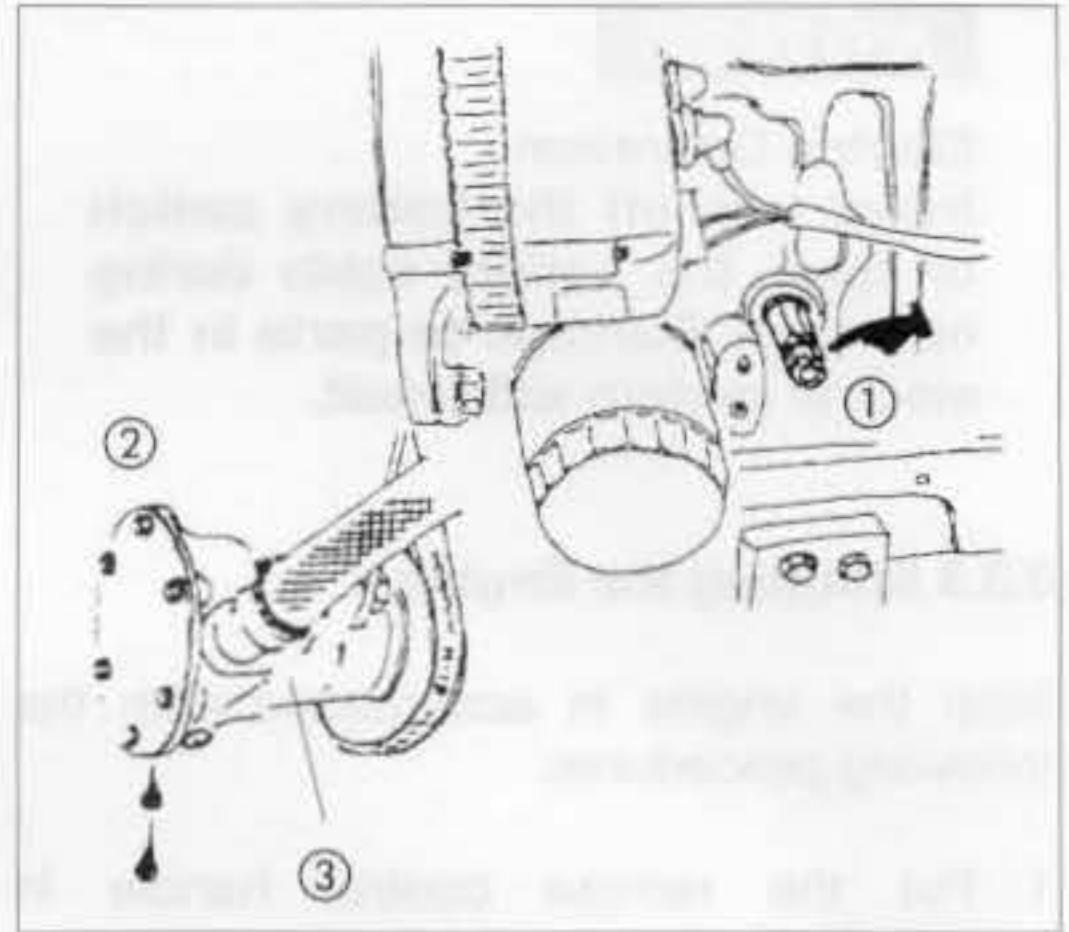

- ① Water drain cock ③ Seawater pump
② Loosen bolts and pull out top

1. Loosen the drain cocks at the side of the cylinder block, and drain off the water inside.
2. Loosen the 6 bolts fixing the side cover of the seawater pump, remove the cover and drain the water from inside. Retighten the bolts when finished.
3. Close the drain cocks.

(2) If antifreeze has not been added to the cooling fresh water, be sure to drain off the water from the fresh water cooling system daily after use.

Fresh Water Cooling

NOTICE

If the water is not removed, it may freeze and damage parts of the cooling water system (fresh water cooler, cylinder block, cylinder head, etc.)

3. Operation

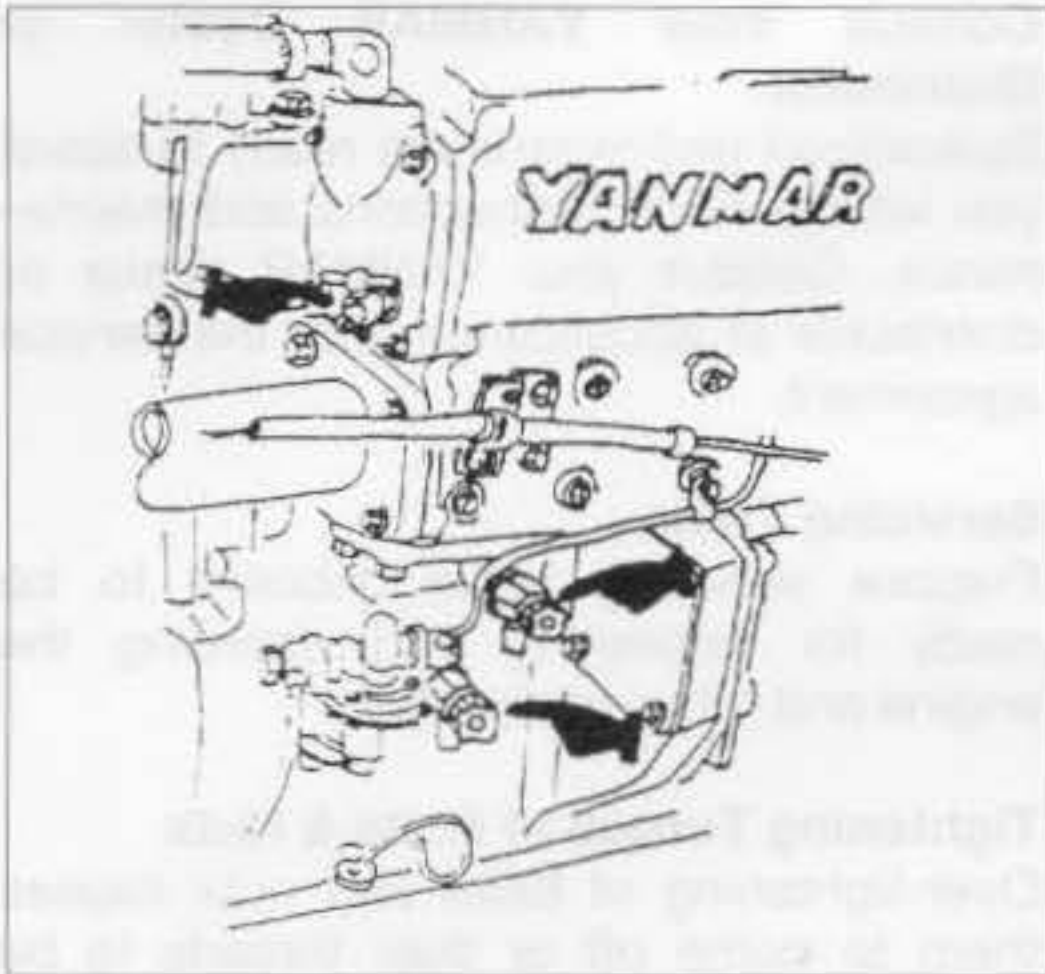

● Cooling water drain cocks

1. Open the water drain cocks (3 positions as illustrated) and drain the cooling water from inside.
2. Close the drain cocks after draining the water.

(3) Carry out the next periodic inspection before placing the engine in storage. Clean the outside of the engine wiping off any dust or oil.

(4) To prevent condensation inside the fuel tank, either drain off the fuel or fill the tank.

(5) Grease the exposed area and joints of the remote control cable and the bearings of the remote control handle.

(6) Cover the intake silencer, exhaust pipe, etc. with vinyl sheets and seal them to prevent moisture from entering.

(7) Drain bilge in the hull bottom completely. Water may leak into the boat when it is moored, and whenever possible it should be landed.

(8) Waterproof the engine room to prevent rain and seawater from entering.

(9) During long term storage, charge the battery once a month to compensate for the battery's self-discharge.

GB

NOTICE

Apply the following tightening torque to bolts having "T" on the head. (See illustration.)
 Tighten bolts with "T" mark to 50% tightening torque.
 If the bolts are tightened with torque wrench, tighten the bolts to 50% tightening torque.

Bolts		Nuts		Washers		Lock washers	
Size	Torque (N·m)	Size	Torque (N·m)	Size	Torque (N·m)	Size	Torque (N·m)
M10	20	M10	15	M10	15	M10	15
M12	30	M12	20	M12	20	M12	20
M14	40	M14	30	M14	30	M14	30
M16	50	M16	40	M16	40	M16	40
M18	60	M18	50	M18	50	M18	50
M20	70	M20	60	M20	60	M20	60
M22	80	M22	70	M22	70	M22	70
M24	90	M24	80	M24	80	M24	80
M27	110	M27	100	M27	100	M27	100
M30	130	M30	120	M30	120	M30	120

4. Maintenance & Inspection

4.1 General Inspection Rules

Conduct Periodic Inspection for Your Safety.

The functions of engine components will degenerate and engine performance will drop according to the use of the engine. If countermeasures are not taken, you may encounter unexpected troubles while cruising at sea. Consumption of fuel or lube oil may become excessive and exhaust gas and engine noise may increase. These all shorten the life of the engine. Daily and periodic inspection and servicing increase your safety at sea.

Inspect Before Starting.

Make it a daily rule to inspect before starting. (See 3.3.1)

Periodic Inspections at Fixed Intervals.

Periodic inspections must be made after every 50, 150, 300 and 600 hours of use. Conduct periodic inspections according to the procedures described in this Operation Manual.

Use Genuine Parts.

Be sure to use genuine parts for consumable and replacement parts. Use of other parts will reduce engine performance and shorten the life of the engine.

Consult Your YANMAR Dealer or Distributor.

Specialized technicians are ready to assist you with periodic inspections and maintenance. Consult your YANMAR dealer or distributor in accordance with the service agreement.

Servicing Tools

Prepare servicing tools onboard to be ready for inspecting and servicing the engine and other equipment.

Tightening Torque of Bolts & Nuts

Over-tightening of bolts and nuts causes them to come off or their threads to be damaged. Insufficient tightening causes oil leakage from the installation face or troubles due to the loosening of bolts. Bolts and nuts must be tightened to the appropriate tightening torque. Important parts must be tightened with a torque wrench to the correct tightening torque and in the right order. Consult with your dealer or distributor if the servicing requires the removal of such parts.

The standard tightening torque for standard bolts & nuts is listed below.

NOTICE

Apply the following tightening torque to bolts having "7" on the head. (JIS strength classification: 7T)

Tighten bolts with no "7" mark to 60% tightening torque.

If the parts to be tightened are made from light alloy aluminum, tighten the bolts to 80% tightening torque.

Bolt dia. x pitch mm	M6x1.0	M8x1.25	M10x1.5	M12x1.75	M14x1.5	M16x1.5
Tightening torque Nm	11 ± 01	26 ± 03	50 ± 05	90 ± 10	140 ± 15	230 ± 20

4. Maintenance & Inspection

4.2 List of Periodic Inspection Items

Daily and periodic inspections are important to keep the engine in its best condition. The following is a summary of inspection and servicing items by inspection interval. Periodic inspection intervals should vary depending on the uses, loads, fuels and lube oils used and handling conditions, and are hard to establish definitively. The following should be treated as a general standard only. Section 4.3 gives a detailed explanation of which parts must be inspected and the procedure for doing so for each interval.

NOTICE

Schedule your own periodic inspection plan according to the operational conditions of your engine and inspect every item. Neglect of periodic inspection may lead to engine troubles and shorten the life of the engine. Inspection and servicing at 600 hours and thereafter require special knowledge and techniques. Consult your Yanmar dealer or distributor.

Inspection Interval	Inspection Item	Inspection Method	Inspection Frequency
Daily	Oil level	Visual	Before starting
	Water level	Visual	Before starting
50 hours	Oil level	Visual	Before starting
	Water level	Visual	Before starting
100 hours	Oil level	Visual	Before starting
	Water level	Visual	Before starting
200 hours	Oil level	Visual	Before starting
	Water level	Visual	Before starting
400 hours	Oil level	Visual	Before starting
	Water level	Visual	Before starting
600 hours	Oil level	Visual	Before starting
	Water level	Visual	Before starting
800 hours	Oil level	Visual	Before starting
	Water level	Visual	Before starting
1000 hours	Oil level	Visual	Before starting
	Water level	Visual	Before starting

GB

4. Maintenance & Inspection

○: Check ●: Replace ●: Consult local dealer

System	Item	Before starting	After 50 hrs or one month	Every 150 hrs	Every 300 hrs	Every 600 hrs (1 year)
Fuel system*	Check the fuel level, and refill	○				
	Drain the fuel tank		○ (first)		○	
	Drain the fuel filter		○			
	Replace the fuel filter				●	
	Check the injection timing					●
	Check the injection spray condition					●
Lubricating system	Check the lube oil level	Crankcase	○			
		Marine gear	○			
	Replace the lube oil	Crankcase		● (first)	●	
		Marine gear		● (first)	●	
	Check the oil pressure warning lamp function	○				
	Replace the lube oil filter		● (first)		●	
Cooling system	Seawater outlet	○ During operation				
	Check cooling water level	○				
	Adjust the tension of cooling water pump driving belt		○ (first)		○	
	Check the impeller of the cooling water pump (seawater pump)					○
	Replace the fresh water cooling			Every year		
	Check and replace the anticorrosion zinc				●	
Air intake and exhaust system	Clean the element of the air intake silencer				○	
	Clean the exhaust/water mixing elbow				○	
	Clean the breather pipe				○	
	Check the exhaust gas condition	○ During operation				
Electrical system	Check the charge lamp function	○				
	Check the electrolyte level in the battery	○		○		
	Adjust the tension of the alternator driving belt		○ (first)		○	
	Check the wiring connectors				○	
Cylinder head, etc.	Check for leakage of water and oil	○ (After starting)				
	Retighten all major nuts and bolts					●
	Adjust intake/exhaust valve clearance		○ (first)			●
Remote control system, etc.	Check the remote control operation		○ (first)			●
	Adjust the propeller shaft alignment		○ (first)			●

*For EPA Requirements, see also 4.4

4. Maintenance & Inspection

4.3 Periodic Inspection Items

4.3.1 Inspection on Initial 50 Hrs. of Operation (or after 1 Month)

(1) Replacing the Engine Lube Oil and Lube Filter (1st time)

During initial operation of the engine, the oil is quickly contaminated due to the initial wear of internal parts. The lube oil must therefore be replaced early. Replace the lube oil filter at the same time.

It is easiest and most effective to drain the engine lube oil after operation while the engine is still warm.

1. Remove the lube oil dipstick. Attach the oil drain pump and drain off oil.
2. Remove the lube oil filter with the filter detach/attach tool. (Turn to the left.)
3. Clean the filter installation face and attach the new filter, tightening by hand.
4. Turn an additional 3/4 of a turn with the attachment tool. (Turn to the right. Tightening torque: 20 ~ 24 Nm)
5. Fill with new lube oil. (See 3.2.2)
6. Perform a trial run and check for oil leakage.
7. Approximately 10 minutes after stopping the engine, remove the oil dipstick and check the oil level. Add oil if the level is too low.

CAUTION

Beware of oil splashes if extracting the lube oil while it is hot.

(2) Replacing the Clutch Lube Oil (1st time)

During initial operation, the oil is quickly contaminated due to the initial wear of internal parts. The lube oil must therefore be replaced early.

1. Remove the cap from the filler port and attach the oil drain pump. Drain off oil.
2. Fill with new lube oil. (See 3.2.3)
3. Perform a trial run and check for oil leakage.

(3) Draining the (optional) Fuel Tank

Open the drain cock and drain off any water or dirt collected on the bottom.

Put a pan under the drain to catch the fuel. Once the water and dirt has been drained off and the fuel coming out is clear, close the drain cock.

4.3.2 Inspection Every 50 Hours (or Monthly)

(1) Draining the Fuel Filter

1. Close the fuel oil cock.
2. Remove the fuel filter cover and drain off any water and dirt collected inside.
3. After reassembly, be sure to vent air from the fuel system. (See 3.3.2(3))

(2) Inspection and Adjustment of Intake/ Exhaust Valve Clearance (1st time)

Settling of a new engine and individual engine use will cause changes in the intake/exhaust valve and rocker arm clearance, and adjustment is necessary. This adjustment requires specialized knowledge and techniques. Consult your Yanmar dealer or distributor.

4. Maintenance & Inspection

(3) Adjusting the Remote Control Cable

The various control levers on the engine side are connected to the remote control lever by the remote control cable. The cable will become stretched and the attachments loose after long hours of use causing deviation. It is dangerous to control operation under these conditions, and the remote control cable must be checked and adjusted periodically.

A) Adjusting the Governor Remote Control Cable

Check to see that the control lever on the engine side moves to the high speed bolt position and low speed bolt position when the remote control lever is moved to H(high speed) and L(low speed) respectively.

When there is deviation, loosen the bracket for the remote control cable on the engine side and adjust.

Adjust the high speed bolt position first and then adjust the low speed idling.

B) Adjusting the Clutch Remote Control Cable

Check to see that the control lever moves to the correct position when the remote control handle is put in NEUTRAL, FORWARD, REVERSE.

Use the NEUTRAL position as the standard for adjustment. When there is deviation, loosen the bracket for the remote control cable on the clutch side and adjust.

(4) Electric Operation

⚠ WARNING

Before inspecting the electrical system, be sure either to turn off the battery switch or to disconnect the (-) terminal of the earth cable. Otherwise, a short-circuit could cause a fire.

Ensure good ventilation when charging the battery. The use of open flames is strictly prohibited. Hydrogen gas may also catch fire.

Battery fluid is diluted sulfuric acid. It can blind you or burn your eyes or skin. Wear goggles and gloves when handling battery fluid. Should the fluid be deposited on your skin, wash with a large quantity of fresh water and seek treatment from a doctor.

1) *If operation continues with insufficient battery fluid, the battery will be destroyed. Check the fluid level periodically. If the level is lower than specified, resupply battery fluid (available in the market) up to the upper limit of the battery.*

(Battery fluid tends to evaporate in high temperatures, especially in summer. In such cases, inspect the battery earlier than specified.)

2) *If the engine speed will not rise and the engine cannot be started, measure the specific gravity with a pycnometre (available in the market).*

The specific gravity of the fluid when fully charged is over 1.27(at 20°C).

Fluid with a specific gravity of below 1.24 needs charging. If the specific gravity cannot be raised by charging, the battery must be replaced.

NOTICE

The capacities of the standard alternator and the recommended battery assume only the power necessary for regular operation.

If the power is also used for inboard lighting or other purposes, the generating and charging capacities may be insufficient. In such cases, consult your Yanmar dealer or distributor.

4. Maintenance & Inspection

4.3.3 Inspection Every 150 hours.

Replace the engine oil and the clutch lube oil.

After the second oil change, the engine oil should be replaced after every 150 hours.

4.3.4 Inspection Every 300 Hrs.

(1) Replacing the Fuel Filter

When there is dirt in the fuel, the filter becomes clogged, and the fuel will not flow easily. Check and replace the inside element.

1. Close the fuel cock.
2. Remove the filter case by loosening the retainer ring (turn to the left) with the filter wrench.
3. Pull the element out from the bottom, and replace with a new one.
4. Clean the inside of the case thoroughly, put on the O-ring, and close with the retainer ring. (Turn to the right. Tightening torque: 12 Nm)
5. Air will enter into the fuel system when the filter is disassembled, and should be vented. (See 3.3.2(3))

(2) Adjusting the Tension of the Cooling Water Pump Driving Belt.

When there is not enough tension in the V-belt, it will slip and the cooling water pump will fail to supply cooling water. Engine over-heating and seizure will result.

When there is too much tension in the V-belt, the belt will become damaged more quickly and the bearing of the cooling water pump may be damaged.

1. Check the tension of the V-belt by pressing down on the middle of the belt with your finger.
With proper flexion, the V-belt should sink 8~10mm.
2. Loosen the set bolt and move the cooling water pump to adjust V-belt tension.
3. Be careful not to get any oil on the V-belt. Oil on the belt causes slipping and stretching. Replace the belt if it is marred.

(3) Adjusting the Tension of the Alternator Driving Belt.

When there is not enough tension in the V-belt, the alternator will not turn and power will not be generated.

When there is too much tension in the V-belt, the belt will become damaged more quickly, and the alternator bearing may be damaged.

1. Check the tension of the V-belt by pressing down on the middle of the belt with your finger.
With proper flexion, the V-belt should sink 8~10mm.
2. Loosen the set bolt and move the alternator to adjust V-belt tension.
3. Be careful not to get any oil on the V-belt. Oil on the belt causes slipping and stretching. Replace the belt if it is marred.

4. Maintenance & Inspection

(4) Inspecting and Replacing Anticorrosion Zinc

The timing for replacing anticorrosion zinc varies depending on the characteristics of the seawater and operational conditions. Inspect the zinc periodically and remove any corroded areas.

Replace the anticorrosion zinc when it has been reduced to less than 1/2 of its original size. If replacement of zinc is neglected and operation is continued with a small volume of anticorrosion zinc, corrosion of the seawater cooling system will occur and water leakage or parts breakage will result. The anticorrosion zinc is on the inside of the anticorrosion zinc plug which is labeled with a sticker reading: Anticorrosion Zinc.

(5) Replacing the Engine Oil and Lube Oil Filter

(See 4.3.1(1))

(6) Cleaning the Intake Silencer

Disassemble the intake silencer and clean the inside thoroughly.

Remove the cover by taking off the clamp. Clean the element with a neutral detergent. Reassemble after it is completely dry.

4.3.5 Inspection Every 600 Hrs.

(1) Replacing Fresh Water Cooling

Cooling performance drops when cooling water is contaminated with rust and scale. Even if antifreeze or antirust is added, the cooling water must be replaced periodically because the properties of the agent will degenerate.

To extract the cooling water, open the cooling water cocks (three places) as shown in 3.4(2).

(Refer to 3.2.4 for resupplying cooling water.)

(2) Inspecting Inner Parts of the Seawater Pump

Depending on the use, the inside parts of the seawater pump deteriorate and discharge performance drops. At the specified interval or when the volume of seawater discharged is reduced, inspect the seawater pump in accordance with the following procedures:

1. Loosen the side cover set bolts and remove the side cover.
2. Illuminate the inside of the seawater pump with a flashlight and inspect.
3. If any of the following problems is found, disassembly and maintenance are necessary:

a) *Impeller blades are cracked or nicked. Edges or surfaces of the blades are marred or scratched.*

Note: The impeller must be replaced periodically (every 1000 hrs.).

b) *Wear plate is damaged.*

4. If no damage is found when inspecting the inside of the pump, reassemble the side cover.

Fit the O-ring to the groove of the joint face before replacing the side cover.

If a large amount of water leaks continuously from the water drain pipe beneath the seawater pump during operation, disassembly and maintenance (replacement of the oil seal) are necessary.

When disassembly and maintenance of the seawater pump are necessary, consult your Yanmar dealer or distributor.

NOTICE

The seawater pump turns in the counterclockwise direction, but the impeller must be installed by turning in the clockwise direction. If the impeller has been removed for any reason and must be

4. Maintenance & Inspection

reassembled, be very careful not to make a mistake and turn it in the wrong direction. Additionally, if the engine is being turned manually, be careful to turn it in the correct direction. Incorrect turning will twist the impeller and damage it.

(3) Inspection and Adjustment of Intake/Exhaust Valve Clearance.

When operating for long periods of time, the clearance between the intake/exhaust valve and the rocker arm will change and affect operation performance. Adjustment is necessary.

Adjustment requires specialized knowledge and techniques. Consult your Yanmar dealer or distributor.

(4) Inspecting and Adjusting the Fuel Injection Spray Condition.

Adjustment is necessary to obtain the optimal fuel injection to ensure the best possible engine performance. This inspection requires specialized knowledge and techniques. Consult your Yanmar dealer or distributor.

(5) Adjusting the Remote Control Cable (See page 38, 4.3.2(3))

(6) Inspecting and Adjusting the Fuel Injection Timing

Fuel injection timing must be adjusted to ensure optimal engine performance.

This maintenance requires specialized knowledge.

Consult your Yanmar dealer or distributor.

4.4 EPA Requirements

4.4.1 EPA Certification Plate

a) 2GM20 (F) series

This engine has the following EPA Certification Plate attached:

- EPA Certification Plate

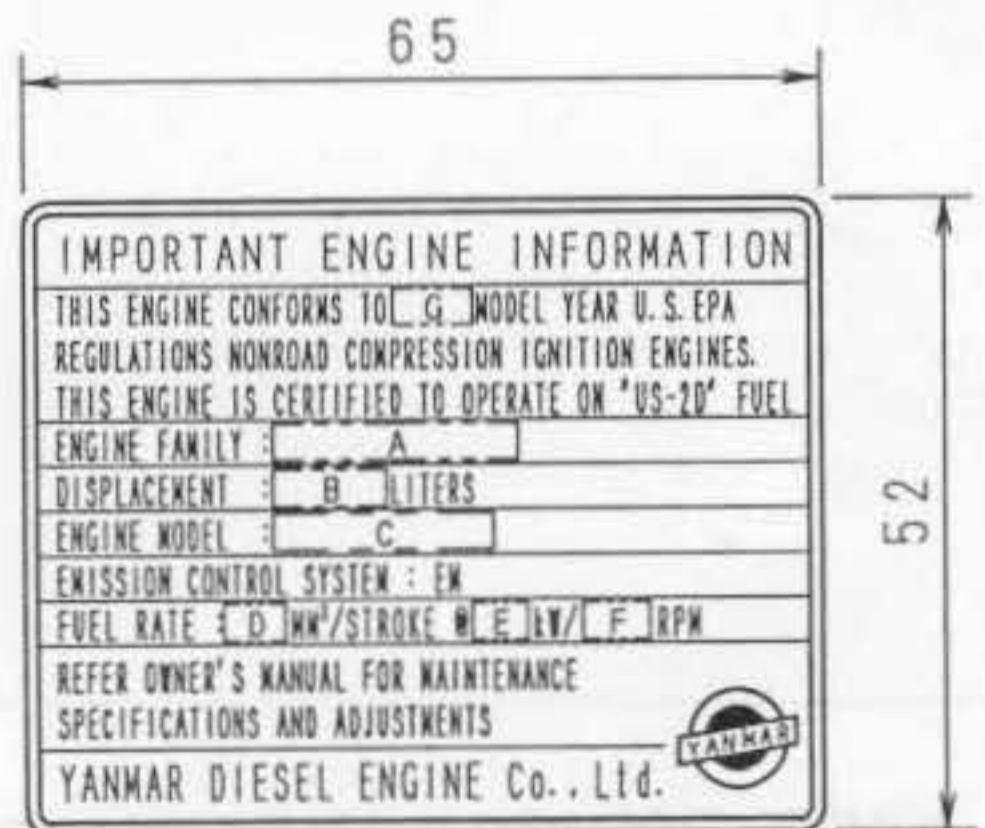

- Attachment Position for Certification Plate

- 2GM20 (C) (V), 2GM20F (C) (V) series:
attached to the intake air silencer side of the bonnet

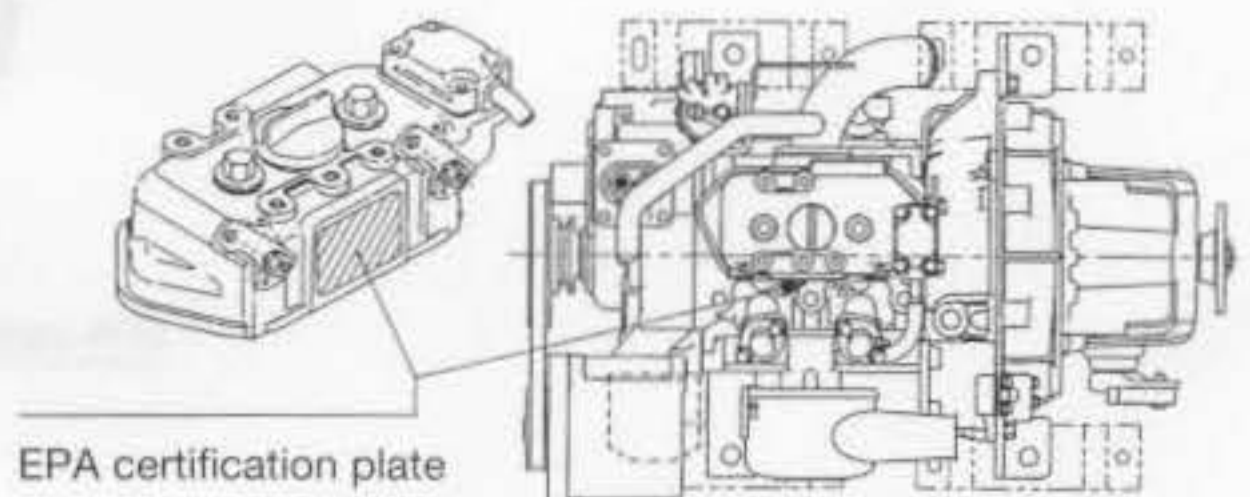

4. Maintenance & Inspection

b) 3GM30 (F) series

This engine has the following EPA Certification Plate attached:

- **EPA Certification Plate**

IMPORTANT ENGINE INFORMATION	
THIS ENGINE CONFORMS TO <input type="checkbox"/> <input type="checkbox"/> MODEL YEAR U. S. EPA REGULATIONS NONROAD COMPRESSION IGNITION ENGINES.	
THIS ENGINE IS CERTIFIED TO OPERATE ON 'US-20' FUEL	
ENGINE FAMILY : <input type="checkbox"/> A <input type="checkbox"/>	DISPLACEMENT : <input type="checkbox"/> B <input type="checkbox"/> LITRES
ENGINE MODEL : <input type="checkbox"/> C <input type="checkbox"/>	EMISSION CONTROL SYSTEM : FM
FUEL RATE : <input type="checkbox"/> D <input type="checkbox"/> LITRES/STROKE @ <input type="checkbox"/> E <input type="checkbox"/> KW / <input type="checkbox"/> F <input type="checkbox"/> RPM	
REFER OWNER'S MANUAL FOR MAINTENANCE SPECIFICATIONS AND ADJUSTMENTS	
YANMAR DIESEL ENGINE Co., Ltd. 	

- **Attachment Position for Certification Plate**

3GM30(C)(V): attached to the exhaust side of the bonnet

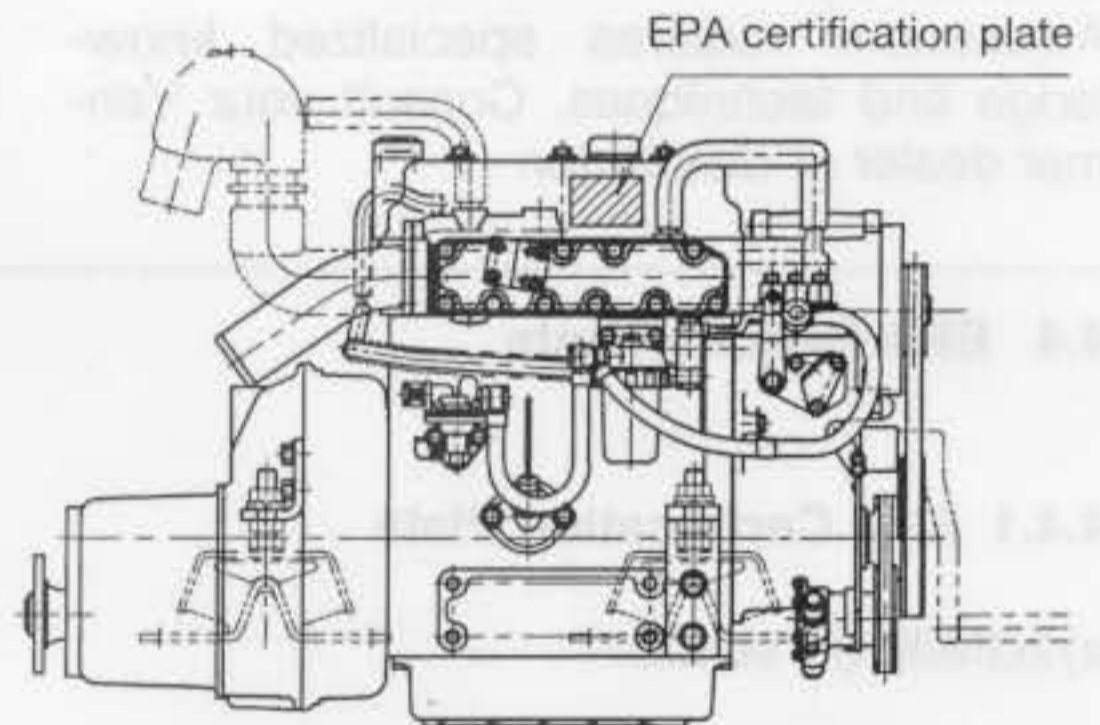

3GM30F(C)(V): attached to the top of the fresh water cooler

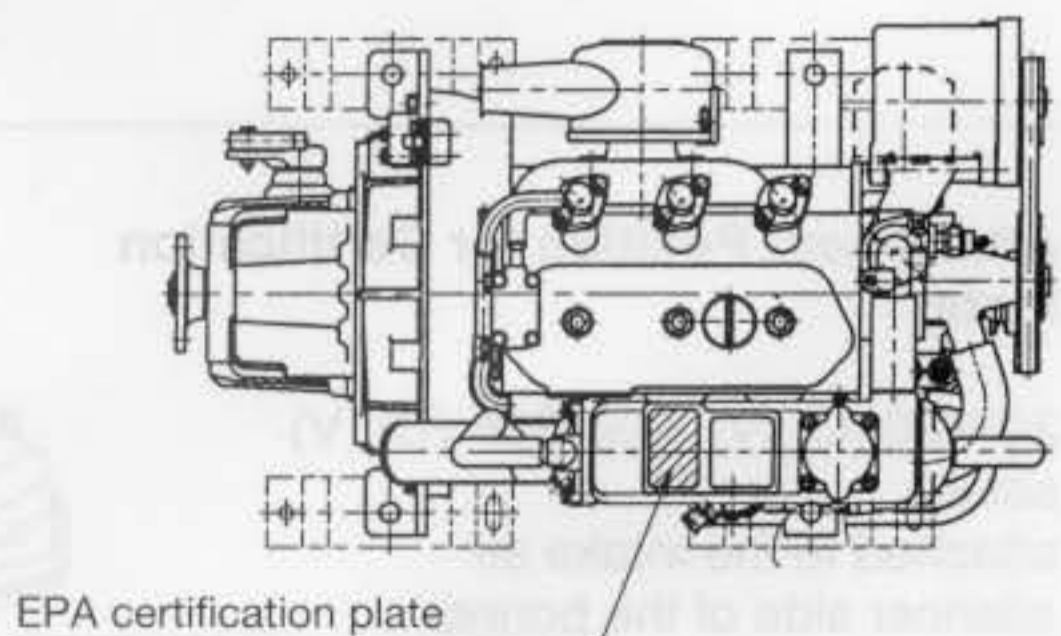

4. Maintenance & Inspection

4.4.2 Conditions to Insure Compliance with Emission Standards

This product is an EPA approved engine. The following are the conditions that must be met in order to insure that the emission during operation meets the EPA standards. Be sure to follow these.

- **The surrounding conditions should be as follows:**
 - a) Ambient temperature: -20 ~ 40°C
 - b) Relative humidity: 80% or lower
 - c) Permissible value for intake negative pressure: 0.5kPa (50mmAq) or lower
 - d) Permissible value for exhaust back pressure: 6.9kPa (700mmAq) or lower
- **The fuel and lube oil used should be as follows:**
 - a) Fuel: The diesel gas oil ISO 8217 DMA, BS 2869 A1 or A2 (Cetane No. 45 minimally.)
 - b) Lube oil: Type API, class CD

- Do not remove the seals limiting the amount of fuel injected and the speed.

- **Be sure to carry out inspections.**
Follow the basic guidelines outlined in 4.3 (Periodic Inspection Items) of this manual and keep a record of the results. Pay particular attention to these important points: replacing the lube oil, lube oil filter, the fuel filter and cleaning the intake silencer element.

Note: Inspections are divided into two sections in accordance with whom is in charge of carrying out the inspection: (the User) and (the Maker).

- **Warranty period for emission parts**
If the schedule of periodic maintenance outlined in 4.4.3 (Inspection and Maintenance) is followed, the warranty period is determined by the age of the engine or the number of hours of operation as indicated below:

Name of parts	Warranty period (hours of operation/age, whichever occurs first)	
	< 19kW	19≤kW<37
Fuel injection pump assembly	1500 / 2	3000 / 5
Fuel injection valve assembly		

4. Maintenance & Inspection

4.4.3 Inspection and Maintenance

Inspection and maintenance for EPA related parts are shown in the chart below.
(Inspection and maintenance not noted below are the same, see 4.2 and 4.3)

Item	Content	Interval term
Fuel oil	Check fuel valve nozzle (clean)	1000
	Check & adjustment of fuel injection pressure & atomizing condition	1000
	Check fuel pump (adjust)	2000

Note: The inspection and maintenance shown above are to be performed at your Yanmar dealer or distributor

4.4.4 Emission System Warranty Statement

EPA/USA EMISSIONS CONTROL WARRANTY STATEMENT

Yanmar Diesel Engine Co., Ltd. (Hereinafter referred to as Yanmar) warrants initial owner and each subsequent owner that the engine is designed, built and equipped so as to conform with applicable regulations for its warranty period.

Specific emissions-related parts and components are warranted for the period of 5 years or 3,000 hours, whichever comes first, after the date of delivery to the initial owner. If any emissions-related part is defective during the warranty period, the part will be repaired or replaced by Yanmar.

To maintain engine performance and compliance with the regulations, the owner is responsible for the performance of the required maintenance listed in the owner's manual during the warranty period.

This emissions warranty does not cover:

1. Failure caused by any of the following:
 - Abuse, neglect, improper maintenance or use of non-genuine parts.
 - Use of fuel oil and lubricating oil not recommended for the engine.
 - Improper application and installation.
2. Add-on or modification affecting engine emissions.
3. Incidental or consequential damage.

The complete engine warranty statement, except for emissions-related parts and components, is provided separately in the "YANMAR WARRANTY HANDBOOK".

5. Trouble and Troubleshooting

Trouble	Probable Cause	Measure	Reference
Alarm Buzzer and Alarm Lamps On During Operation	<p>NOTICE</p> <p>Shift to low speed operation immediately, and check which lamp has come on. Stop the engine for inspection. If no abnormality is identified and there is no problem with operation, return to port at your lowest speed and request repairs.</p>		
Eng.Lube Oil Press. Warning Lamp goes on	Engine Lube Oil insufficient; Fuel filter clogged.	Check Lube Oil level. Replenish or replace.	3.2.2 4.3.1(1)
*Water proof warning lamp goes on	Breakage of seal mount on the sail drive.	Check and change the rubber mount.	
C.W.Temp.(Fresh Water) warning lamp goes on	Insufficient water in fresh water cooler. Insufficient seawater causing temp. to rise. Contamination inside cooling system.	Check cooling water and replenish. Check seawater system. Ask for repairs.	3.2.4
Faulty Warning Devices	<p>NOTICE</p> <p>Do not operate the engine if alarm devices are not repaired. Serious accidents may result if difficulties are not spotted due to faulty alarm lamps. When switch is turned ON: Alarm buzzer does not sound. Circuit broken or buzzer defective. Ask for repairs.</p>		
Warning lamps do not go on	Eng. Lube Oil Press. Seawater. No current available. Circuit broken or lamp burnt out.	Ask for repairs.	
One of the warning lamps does not go out	Sensor switches faulty.	Ask for repairs.	
Charge lamp does not go out during operation	V-belt is loose or broken. Battery defective. Alternator power generator failure.	Replace V-belt; adjust tension. Check fluid level, specific gravity; replace. Ask for repairs.	4.3.4(3) 4.3.2(4)

*Note: Other warning lamps do not go on when the switch is turned on. They only go on when there is an abnormality.

5. Trouble and Troubleshooting

Trouble	Probable Cause	Measure	Reference
Starting Failures			
Starter turns, but engine does not start	No fuel. Fuel filter is clogged. Improper fuel. Faulty fuel injection. Compression leakage from intake/exhaust valve.	Replenish fuel; vent air. Replace element. Replace with recommended fuel. Ask for repairs. Ask for repairs.	3.3.2(3) 4.3.4(1)
Starter does not turn or turns slowly (Engine can be turned manually)	Faulty clutch position. Insufficient battery charge. Cable terminal contact failure. Faulty safety switch device. Faulty starter switch. Power lacking due to other use.	Shift to NEUTRAL and start. Check fluid lever; recharge; replace. Remove rust from terminal; retighten. Ask for repairs. Ask for repairs. Ask for repairs. Consult your dealer.	3.3.2(1) 4.3.2(4)
Engine cannot be turned manually	Internal parts seized; broken.	Ask for repairs.	
Abnormal Exhaust Colour Black smoke	Load increased. Contaminated intake silencer. Improper fuel. Faulty spraying of fuel injection valve. Incorrect intake/exhaust valve head clearance.	Inspect propeller. Clean element. Replace with recommended fuel. Ask for repairs. Ask for repairs.	4.3.4(6) 3.1.1
White smoke	Improper fuel. Faulty spraying of fuel injection valve. Fuel injection timing off. Lube oil burns; excessive consumption.	Ask for repairs. Ask for repairs. Ask for repairs. Ask for repairs.	3.1.1

Consulting Your Yanmar Dealer or Distributor

Refer difficult problems and repairs to your Yanmar dealer or distributor.
At the time of trouble, check and report the following:

1. Engine model and number:
2. Boat name, material of hull, size (tons):
3. Use, type of fishing done, no. of hours run:
4. Total no. of operation hours (refer to hour metre), age of boat:
5. Condition before trouble (engine rpm, type of operation, load condition, etc.):
6. Details of trouble:
(exhaust colour; sound of engine; does engine start; can engine be turned manually; type of fuel used; brand and viscosity of lube oil; etc.)
7. Past problems and repairs:

5. Trouble and Troubleshooting

WARRANTY SERVICE

Owner Satisfaction

Your satisfaction and goodwill are important to us and to your dealer.

Normally any problems concerning the product will be handled by our dealer's service department. If you have a warranty problem that has not been handled to your satisfaction, we suggest you take the following action:

- Discuss your problem with a member of the dealership management. Complaints can often quickly be resolved at this level. If the problem has already been reviewed with the Service Manager, contact the owner of the dealership or the General Manager.
- If your problem still has not been resolved to your satisfaction, contact your local Yanmar Subsidiary Company. (See the back of this manual for addresses)

We will need the following information in order to assist you:

- Your name, address and telephone number
- Product model and serial number
- Purchase date
- Dealer's name and address
- Nature of the problem

After reviewing all the facts involved, you will be advised of what action can be undertaken. Please remember that your problem will most likely be resolved at the dealership, using the dealer's facilities, equipment and personnel. It is therefore very important that your initial contact be with the dealer.

6. Piping diagrams

(See appendix A at the back of this book)

NOTATION	
————	Fuel oil pipe
— · — ·	Lubricating oil pipe
— · · ·	Cooling water pipe
=====	Drilled hole
⊥—	Screw Joint (Rectangular)
—⊥—	Screw Joint (Union)
—□—	Rubber Joint
—◇—	Cock
STP	Steel pipe
RH	Rubber hose
VH	Vinyl pipe

- 16 Cooling water pump
- 17 Lubricating oil pressure adjusting valve
- 18 Lubricating oil filter (outlet side)
- 19 Oil pressure switch
- 20 Thermostat
- 21 Water temperature switch
- 22 To valve rocker arm

11-3 2GM20F

- 1 Fuel injection valve
- 2 Fuel oil return pipe
- 3 Exhaust gas and cooling water outlet
- 4 Mixing elbow
- 5 Heat exchanger
- 6 Fuel inlet pipe
- 7 Fuel feed pump
- 8 Fuel filter
- 9 Cooling water pump (seawater)
- 10 Seawater
- 11 Kingston cock
- 12 Cooling water pump (fresh water)
- 13 Thermostat
- 14 Fuel injection pump
- 15 Lubricating oil pump
- 16 Lubricating oil inlet filter
- 17 Lubricating oil pressure adjusting valve
- 18 Lubricating oil outlet filter
- 19 Lubricating oil pressure switch
- 20 To main bearing
- 21 To valve rocker arm
- 22 Exhaust manifold

11-4 3GM30F

- 1 Fuel injection valve
- 2 Fuel oil return pipe
- 3 Exhaust gas and cooling water outlet
- 4 Mixing elbow
- 5 Heat exchanger
- 6 Fuel inlet pipe
- 7 Fuel feed pump
- 8 Fuel filter
- 9 Cooling water pump (seawater)
- 10 Seawater
- 11 Kingston cock
- 12 Cooling water pump (fresh water)
- 13 Thermostat
- 14 Fuel injection pump
- 15 Lubricating oil pump
- 16 Lubricating oil inlet filter
- 17 Lubricating oil pressure adjustment valve
- 18 Lubricating oil outlet filter
- 19 Lubricating oil pressure switch
- 20 To main bearing
- 21 To valve rocker arm
- 22 Exhaust manifold

11-5 2GM20V

- 1 Fuel injection nozzle
- 2 Fuel return pipe
- 3 V-drive oil cooler
- 4 V-drive system (for local installation)
- 5 Exh. gas/C.W.
- 6 Mixing elbow
- 7 Fuel inlet
- 8 Fuel feed pump
- 9 Fuel filter
- 10 Lube oil filter inlet side
- 11 Fuel injection pump
- 12 Lube oil pump
- 13 Kingston cock
- 14 C.W. pump
- 15 Thermostat
- 16 Lube oil press. control valve
- 17 Lube oil filter outlet side
- 18 Oil press. switch
- 19 Water temp. switch
- 20 Accessories (for local installation)
- 21 To main bearing
- 22 To main bearing
- 23 To valve rocker arm

11-6 3GM30V

- 1 Fuel injection nozzle
- 2 Fuel return pipe
- 3 V-drive system (for local installation)
- 4 V-drive oil cooler
- 5 Exh. gas/C.W.
- 6 Mixing elbow
- 7 Fuel inlet
- 8 Fuel feed pump
- 9 Fuel filter
- 10 Lube oil filter inlet side
- 11 Fuel injection pump
- 12 Lube oil pump
- 13 Kingston cock
- 14 C.W. pump
- 15 Lube oil press. control valve
- 16 Lube oil filter outlet side
- 17 Oil press. switch
- 18 Thermostat
- 19 Water temp. switch
- 20 Accessories (for local installation)
- 21 To main bearing
- 22 To valve rocker arm
- 23 To cam shaft bearing

11-7 2GM20FV

- 1 Fuel injection nozzle
- 2 Fuel return pipe
- 3 V-drive oil cooler
- 4 V-drive system (for local installation)
- 5 Exh. gas/C.W.
- 6 Mixing elbow
- 7 Heat exchanger
- 8 Fuel inlet pipe
- 9 Fuel feed pump

11-1 2GM20

- 1 Cooling water drain
- 2 Fuel injection valve
- 3 Fuel oil return pipe
- 4 To main bearing
- 5 To main bearing
- 6 To valve rocker arm
- 7 Exhaust gas and cooling water
- 8 Mixing elbow
- 9 Fuel inlet
- 10 Fuel feed pump
- 11 Fuel filter
- 12 Lubricating oil filter (inlet side)
- 13 Fuel injection pump
- 14 Lubricating oil pump
- 15 Cooling water pump
- 16 Kingston cock
- 17 Lubricating oil pressure adjusting valve
- 18 Lubricating oil filter (outlet side)
- 19 Oil pressure switch
- 20 Thermostat
- 21 Water temperature switch

11-2 3GM30

- 1 Cylinder block drain
- 2 Fuel injection valve
- 3 Fuel oil return pipe
- 4 To main bearing
- 5 Exhaust gas and cooling water
- 6 Mixing elbow
- 7 Exhaust manifold drain
- 8 Fuel inlet
- 9 To camshaft bearing
- 10 Fuel feed pump
- 11 Fuel filter
- 12 Lubricating oil filter (inlet side)
- 13 Fuel injection pump
- 14 Lubricating oil pump
- 15 Kingston cock

6. Piping diagrams

- 10 Fuel filter
- 11 Kingston
- 12 Seawater
- 13 C.W. (fresh water) pump
- 14 C.W. (seawater) pump
- 15 Thermostat
- 16 Fuel injection pump
- 17 Lube oil pump
- 18 Lube oil filter inlet side
- 19 Lube oil press. control valve
- 20 Lube oil filter outlet side
- 21 Lube oil press. switch
- 22 Accessories (for local installation)
- 23 To main bearing
- 24 To valve rocker arm
- 25 Exhaust manifold

11-8 3GM30FV

- 1 Fuel injection nozzle
- 2 Fuel return pipe
- 3 V-drive system (for local installation)
- 4 V-drive oil cooler
- 5 Exh. gas/C.W.
- 6 Mixing elbow
- 7 Heat exchanger
- 8 Fuel inlet pipe
- 9 Fuel feed pipe
- 10 Fuel filter
- 11 Kingston cock
- 12 Seawater
- 13 C.W. (fresh water) pump
- 14 Thermostat
- 15 C.W. (seawater) pump
- 16 Fuel injection pump
- 17 Lube oil pump
- 18 Lube oil filter inlet side
- 19 Lube oil press. control valve
- 20 Lube oil filter outlet side
- 21 Lube oil press. switch
- 22 Accessories (for local installation)
- 23 To main bearing
- 24 To valve rocker arm
- 25 Exhaust manifold

11-9 2GM20FC

- 1 Fuel injection valve
- 2 Fuel oil return pipe
- 3 Exhaust gas and cooling water outlet
- 4 Mixing elbow
- 5 Fresh water cooler
- 6 Fuel inlet
- 7 Fuel feed pump
- 8 Fuel filter
- 9 Cooling water pump (seawater)
- 10 Seawater
- 11 From drive
- 12 Cooling water pump (fresh water)
- 13 Thermostat
- 14 Fuel injection pump
- 15 Lubricating oil pump
- 16 Lubricating oil strainer

- 17 Lubricating oil pressure adjusting valve
- 18 Lubricating oil filter
- 19 Lubricating oil pressure switch
- 20 To main bearing
- 21 To valve rocker arm
- 22 Exhaust manifold

11-10 2GM20C

- 1 Fuel injection valve
- 2 Fuel oil return pipe
- 3 Exhaust gas and cooling water outlet
- 4 Mixing elbow
- 5 Fuel inlet pipe
- 6 Fuel feed pump
- 7 Fuel filter
- 8 Lubricating oil strainer
- 9 Fuel injection pump
- 10 Lubricating oil pump
- 11 Kingston Cock
- 12 Cooling water pump (seawater)
- 13 Lubricating oil pressure adjusting valve
- 14 Lubricating oil strainer
- 15 Lubricating oil pressure switch
- 16 Thermostat
- 17 Cooling water temperature switch
- 18 To main bearing
- 19 To main bearing
- 20 To valve rocker arm

11-11 3GM30FC

- 1 Fuel injection valve
- 2 Fuel oil return pipe
- 3 Exhaust gas and cooling water outlet
- 4 Mixing elbow
- 5 Fresh water cooler
- 6 Fuel inlet
- 7 Fuel feed pump
- 8 Fuel filter
- 9 Cooling water pump (seawater)
- 10 Seawater
- 11 From drive
- 12 Cooling water pump (fresh water)
- 13 Thermostat
- 14 Fuel injection pump
- 15 Lubricating oil pump
- 16 Lubricating oil strainer
- 17 Lubricating oil pressure adjusting valve
- 18 Lubricating oil filter
- 19 Lubricating oil pressure switch
- 20 To main bearing
- 21 To valve rocker arm
- 22 Exhaust manifold

11-12 3GM30C

- 1 Fuel injection valve
- 2 Fuel oil return pipe
- 3 Exhaust gas and cooling water outlet
- 4 Mixing elbow
- 5 Fuel inlet pipe
- 6 Fuel feed pump
- 7 Fuel filter
- 8 Lubricating oil strainer
- 9 Fuel injection pump
- 10 Lubricating oil pump
- 11 Seawater
- 12 From drive
- 13 Cooling water pump (seawater)
- 14 Lubricating oil pressure adjusting valve
- 15 Lubricating oil filter
- 16 Lubricating oil pressure switch

7. Wiring diagrams

(See appendix B at the back of this book)

Colour coding	
R	Red
B	Black
W	White
Y	Yellow
L	Blue
G	Green
O	Orange
Lg	Light green
Lb	Light blue
Br	Brown
P	Pink
Gr	Gray
Pu	Purple
$1 + 2 + 3 < 2.5 \text{ m} \rightarrow 20 \text{ mm}^2$ $1 + 2 + 3 < 5 \text{ m} \rightarrow 40 \text{ mm}^2$ (Cross sectional area)	

12-1 For the A-type instrument panel

OPTION (OLD A PANEL)

- 1 Procured by customer
- 2 Battery
- 3 Battery switch
- 4 Option
- 5 Neutral switch
- 6 For 2GM20, 3GM30
- 7 Fuse
- 8 S or C
- 9 Starter
- 10 Earth bolt
- 11 Alternator
- 12 Rubber seal switch
- 13 Sail-drive only
- 14 Spare connector
- 15 Eng. oil pressure switch
- 16 C. W. Temp. switch
- 17 Wire harness
- 18 Earth
- 19 Amplifier
- 20 Sail-drive only
- 21 Detail of connector (View A-A)
- 22 Adapter (Wire harness)
- 23 Sail-drive
- 24 Buzzer
- 25 (Sail-drive only)
- 26 Rubber seal
- 27 Oil pressure
- 28 Cool. Fresh Water Temp.
- 29 Charge
- 30 Push button switch
- 31 Key switch
- 32 Detail of connector (View B-B)

12-2 For the B-type instrument panel

NEW B PANEL

- 1 Procured by customer
- 2 Battery
- 3 Battery switch
- 4 Option
- 5 Neutral switch
- 6 For 2GM20, 3GM30
- 7 Fuse
- 8 S or C
- 9 Starter
- 10 Earth bolt
- 11 Alternator
- 12 Rubber seal switch
- 13 Sail-drive only
- 14 Tacho sensor
- 15 Eng. oil pressure switch
- 16 Cool. water temp. switch
- 17 Wire harness
- 18 Earth
- 19 Amplifier
- 20 Sail-drive only
- 21 Detail of connector (View A-A)
- 22 Detail of connector (View C-C)
- 23 Starter switch
- 24 Fuel tank empty
- 25 Not used
- 26 Rubber seal
- 27 Cool. water temp.
- 28 Engine oil press.
- 29 Charge
- 30 Tacho with hour meter
- 31 Buzzer
- 32 Buzzer stop
- 33 Illumination
- 34 Detail of connector (View B-B)

11-2 3GM30

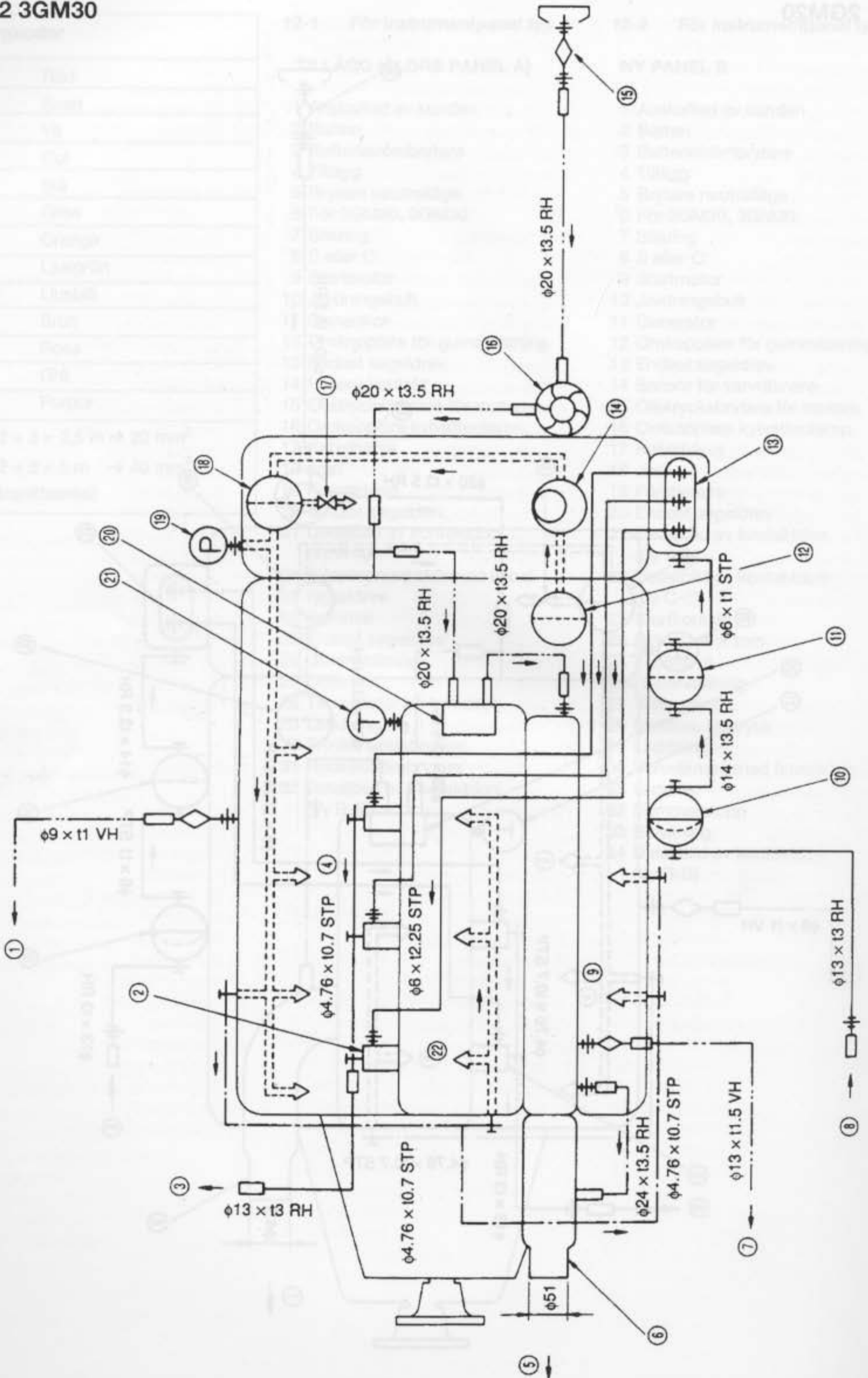

11-3 2GM20F

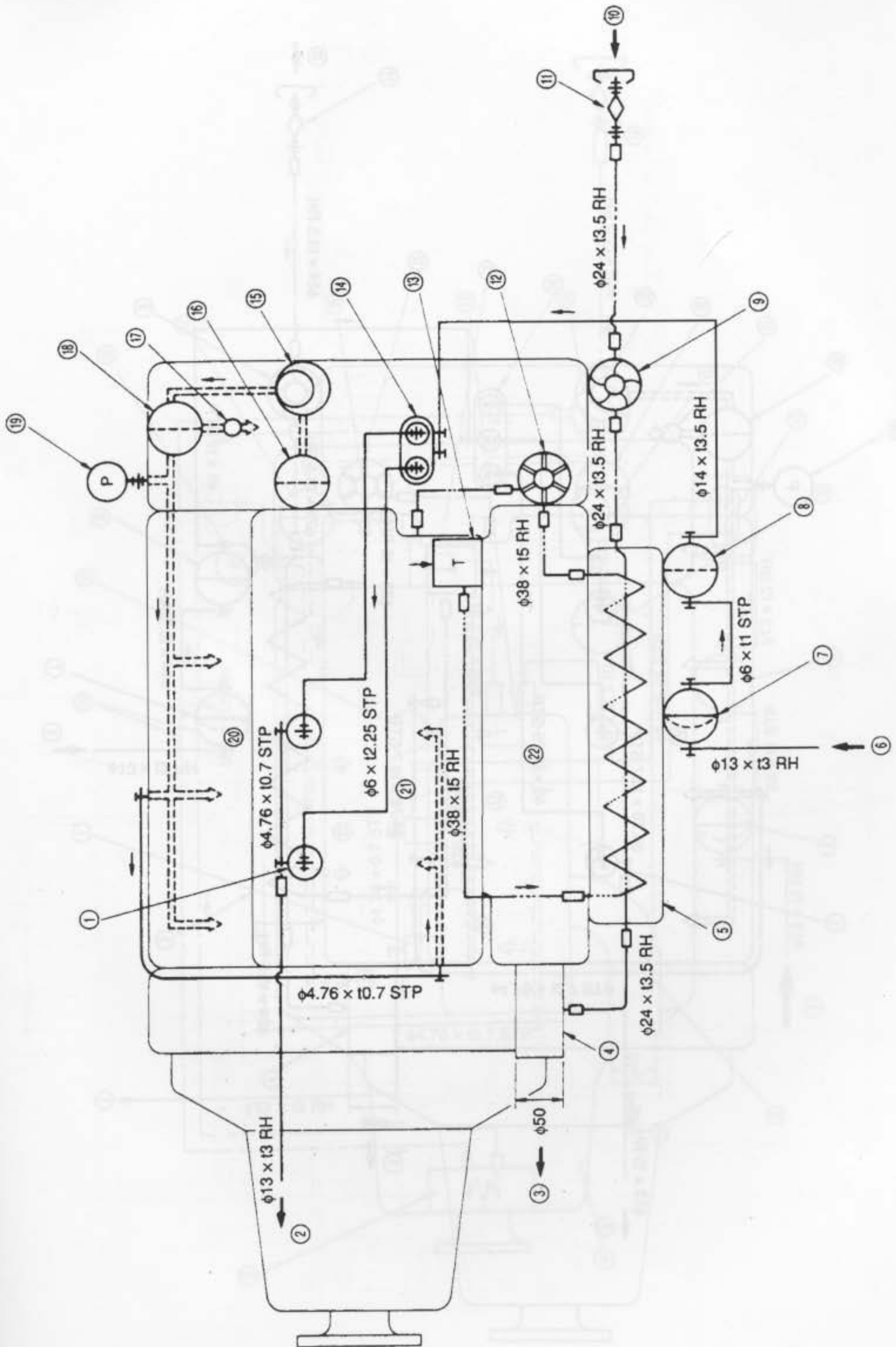

A

11-5 2GM20V

FORM NO. 06-71

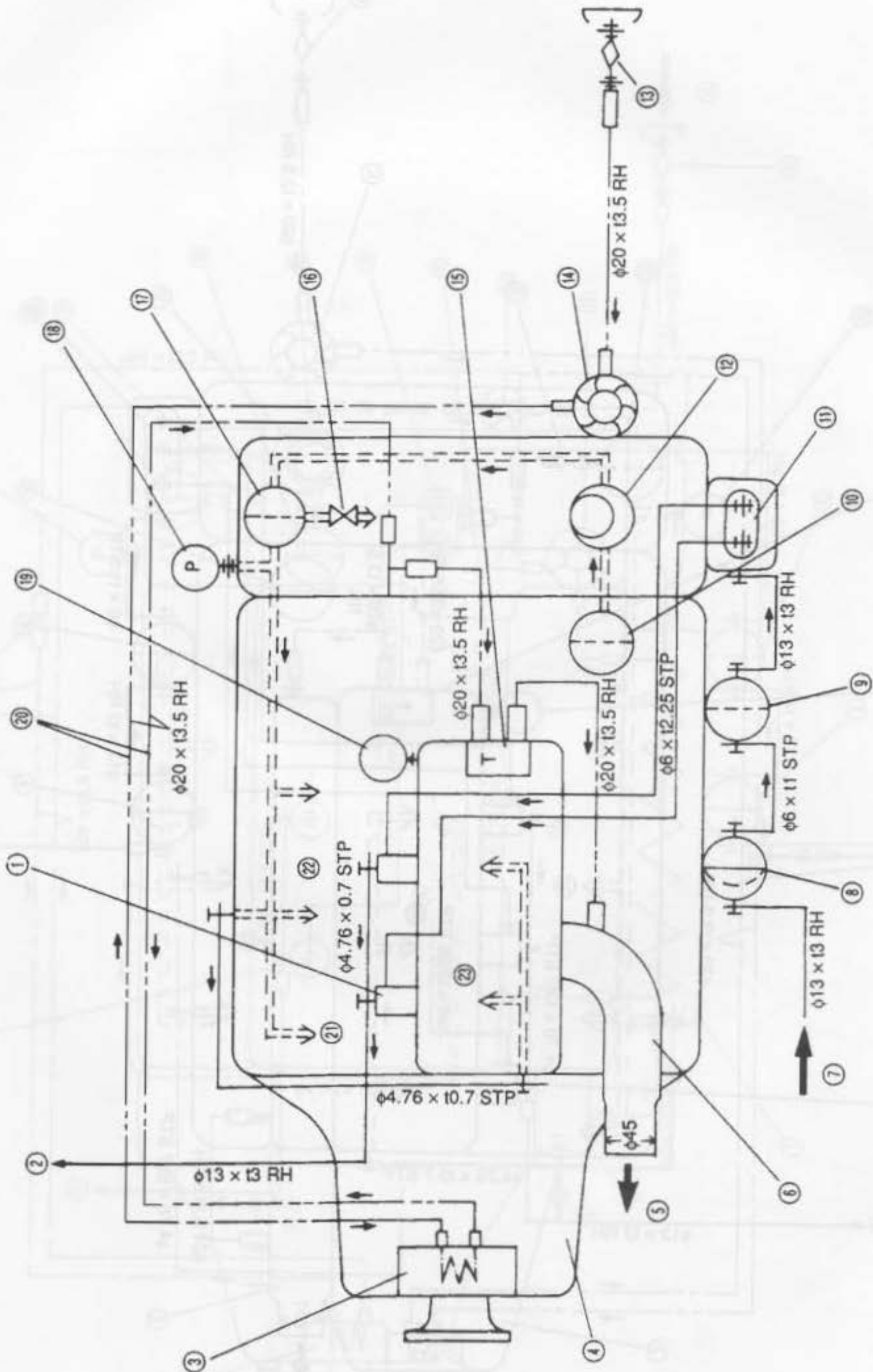

A

11-6 3GM30V

VOISNOR 2-11

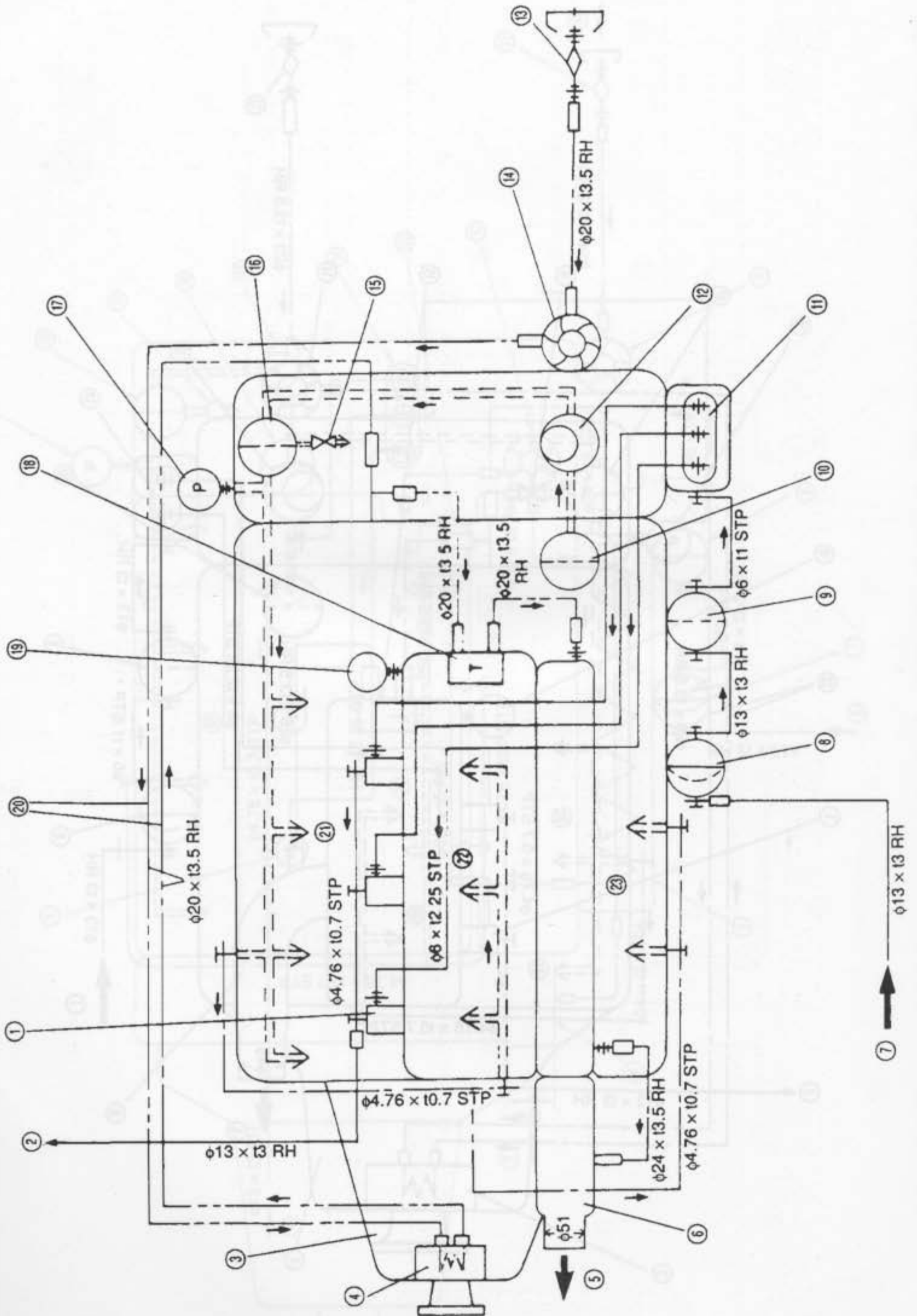

11-7 2GM20FV

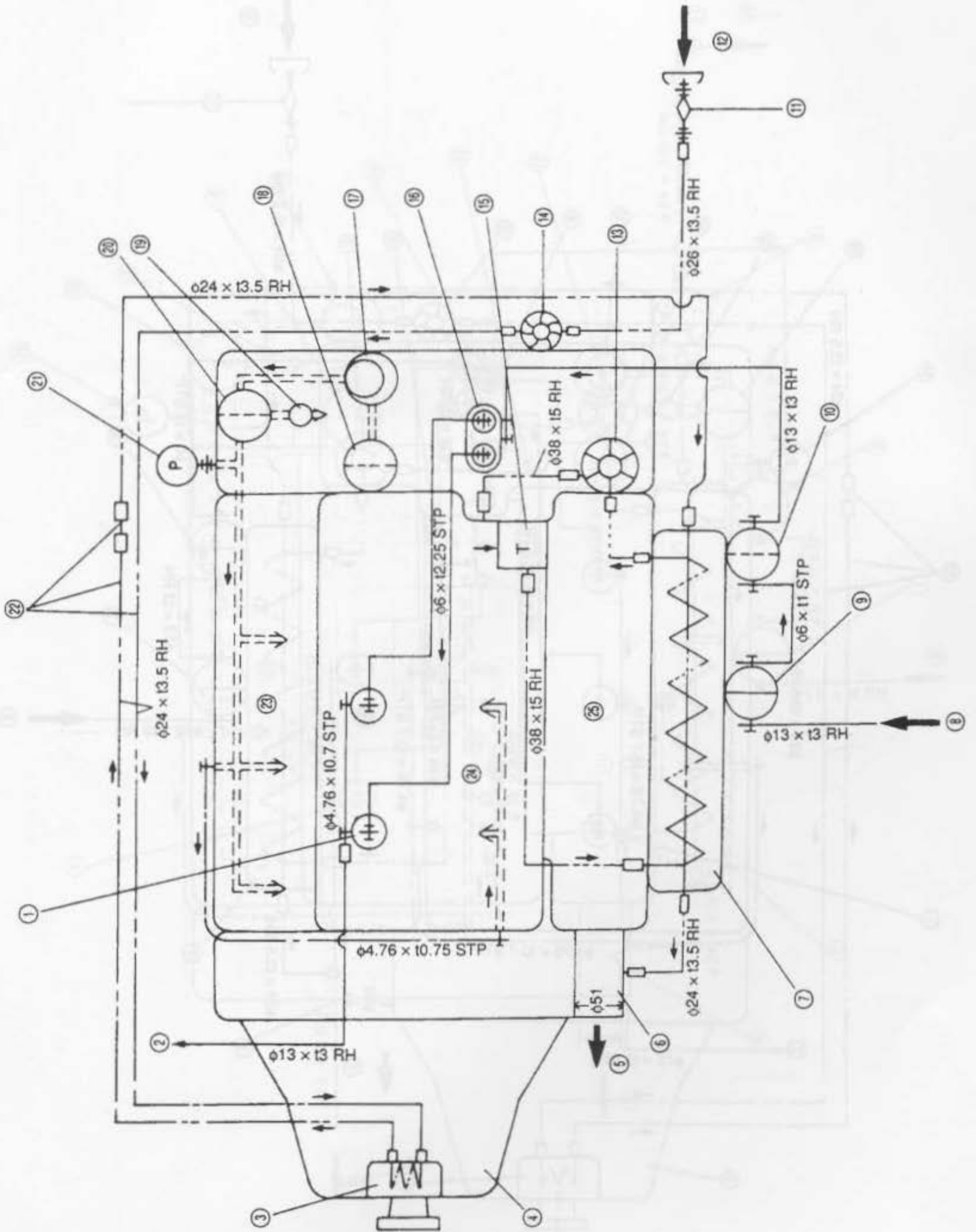

A

11-8 3GM30FV

11-7 3GM30FV

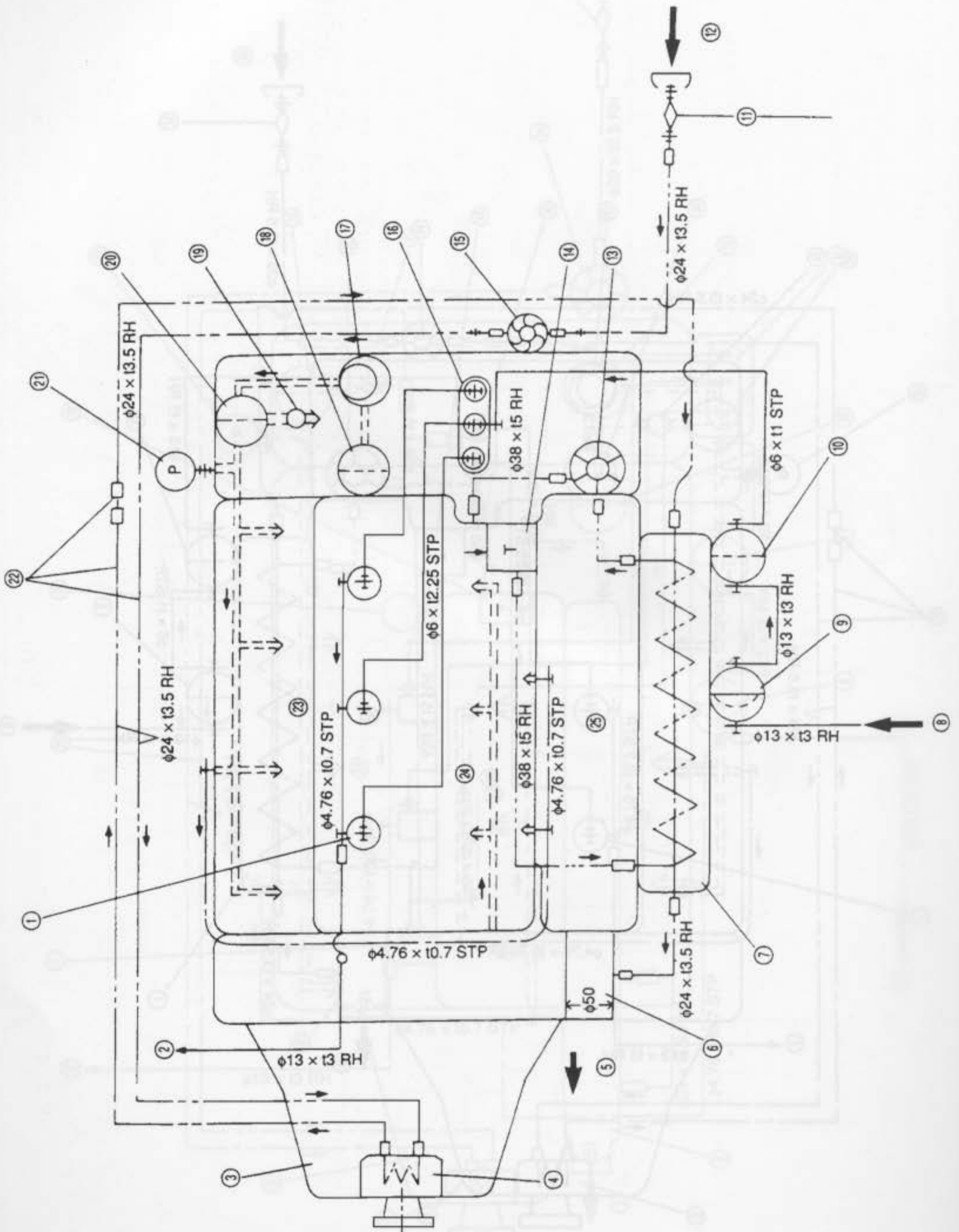

11-9 2GM20FC

COMBOS OF-11

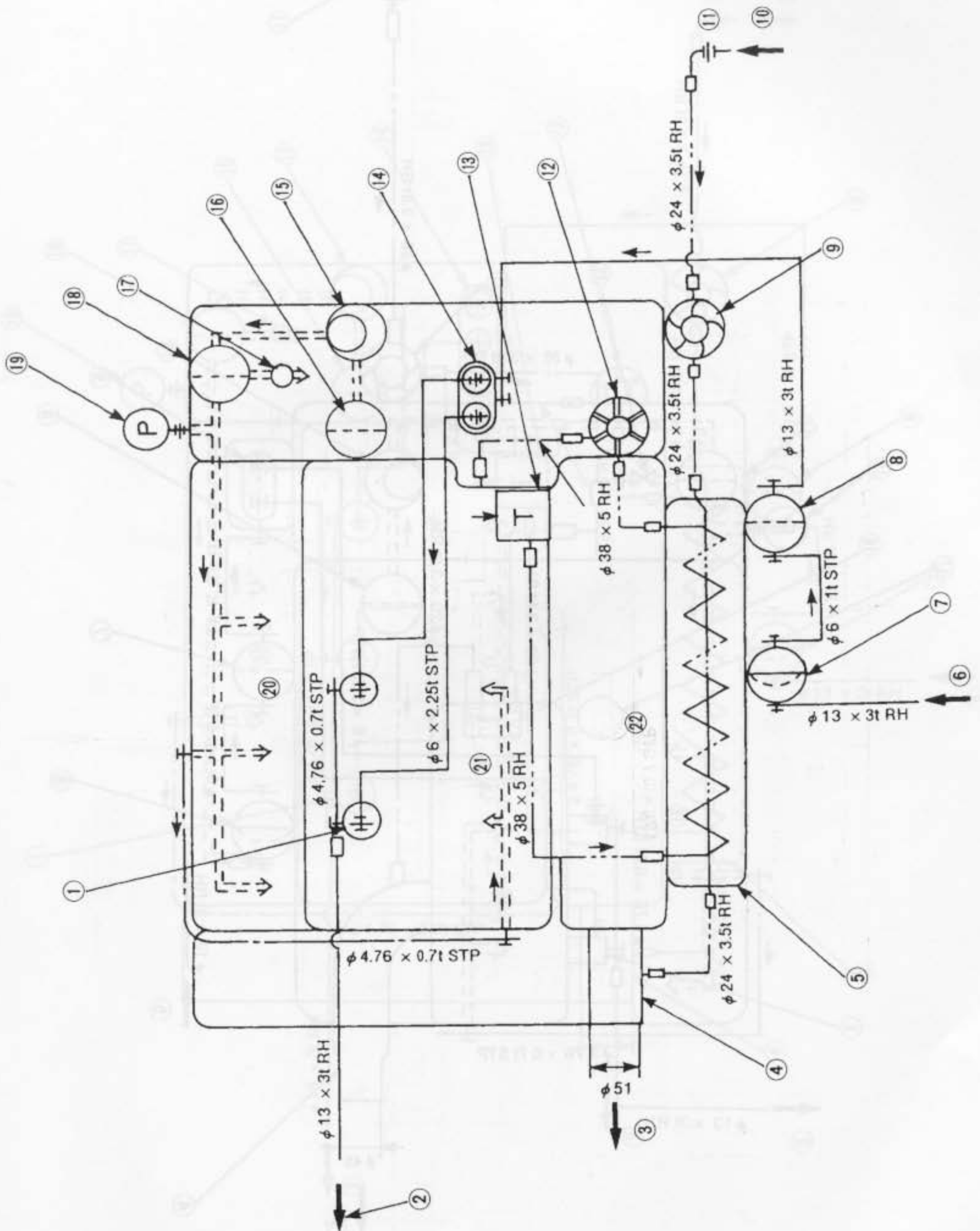

11-10 2GM20C

DRSMD5 B-11

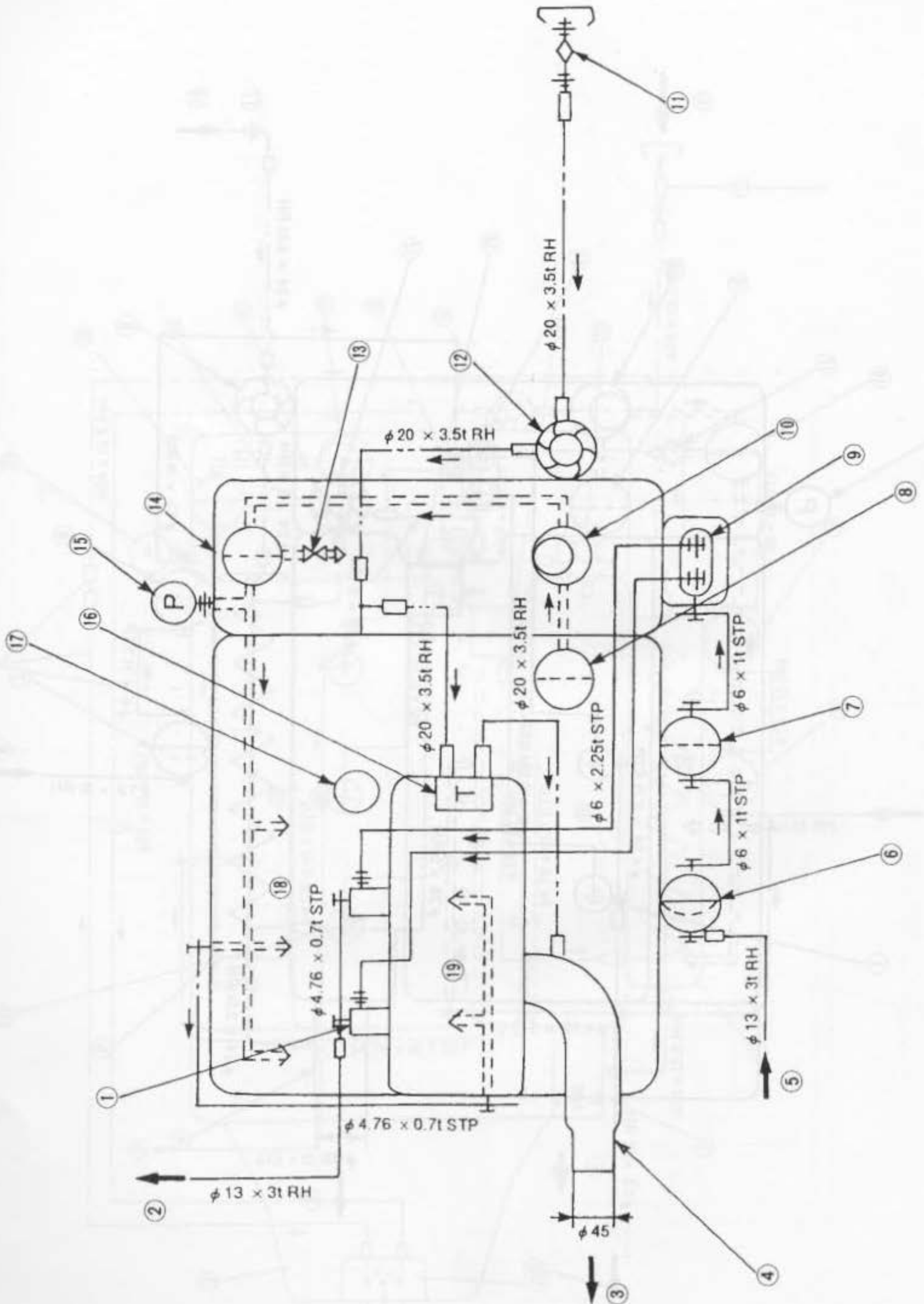

11-11 3GM30FC

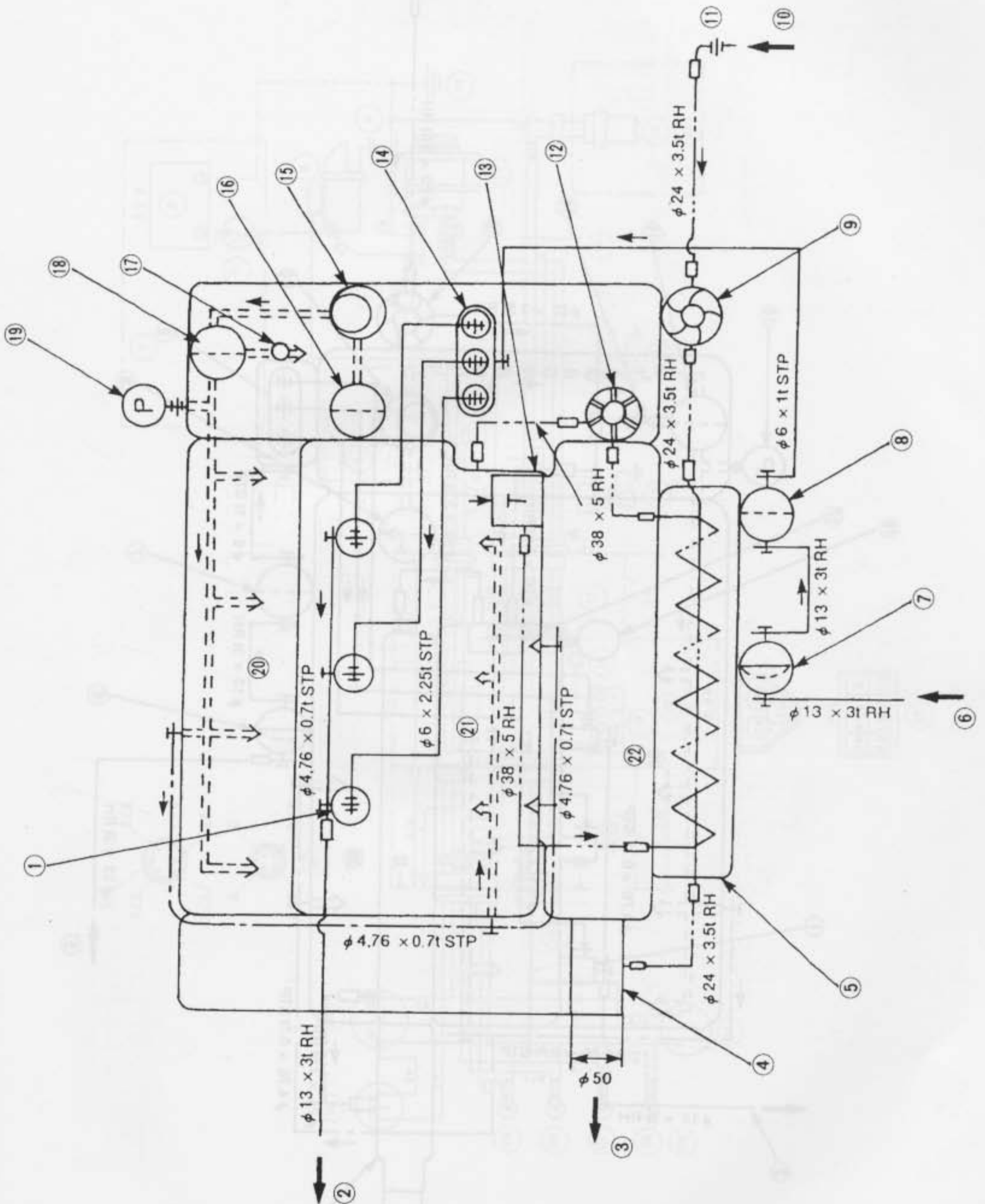

11-12 3GM30C

DRUGA05-11-21

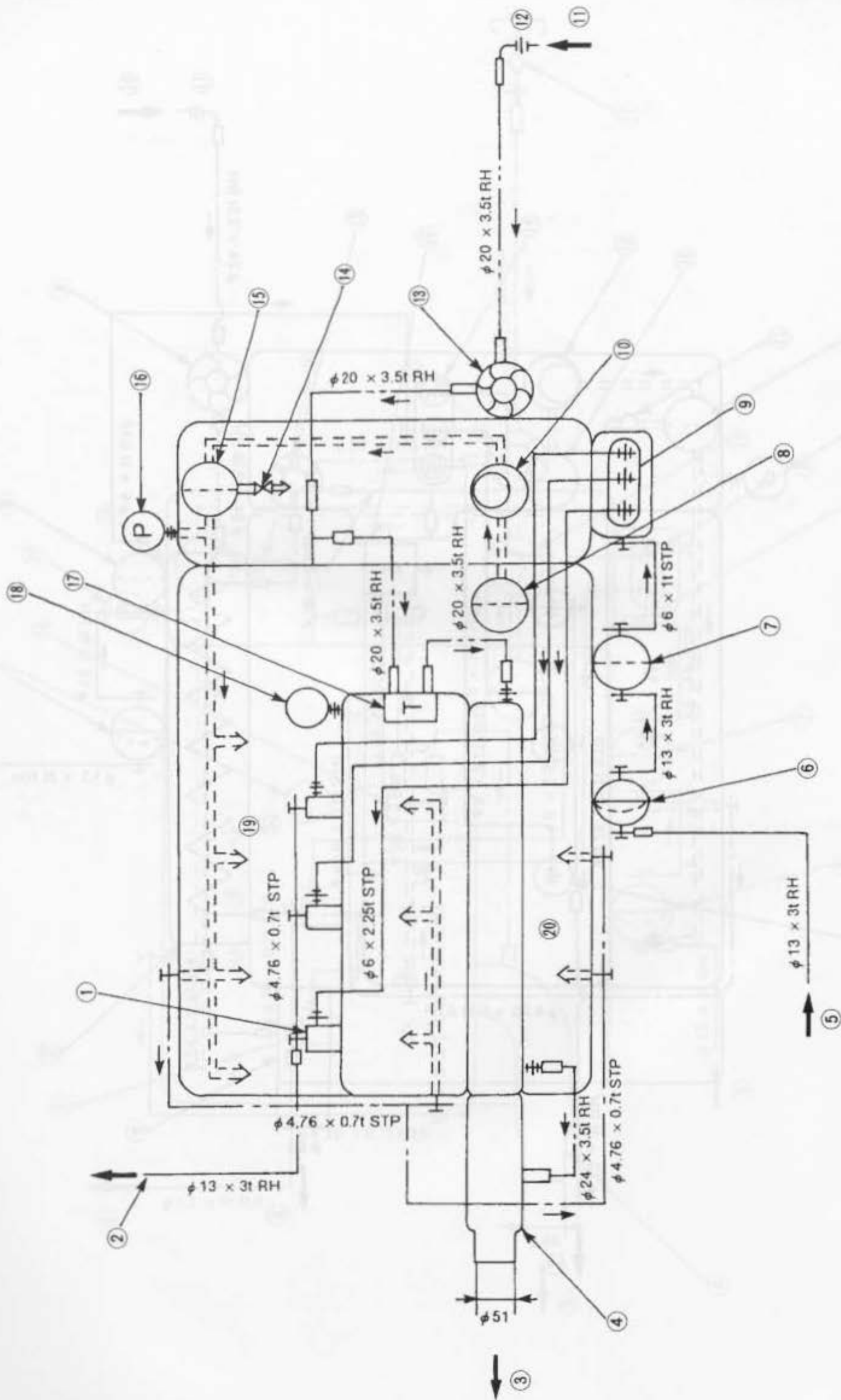

YANMAR DIESEL ENGINE

GM-Series

CAUTION: Overcranking engine with water lift muffler can cause damage!

Bedienungsanleitung (D)

Betjeningsmanual (DK)

Manual de instrucciones (E)

Manual d'utilisation (F)

Käyttöohje (FIN)

Operation Manual (GB)

Εγχειρίδιο λειτουργίας (GR)

Manuale d'istruzioni (I)

Driftshåndbok (N)

Bedieningshandleiding (NL)

Manual de instruções (P)

Driftsinstruktion (S)

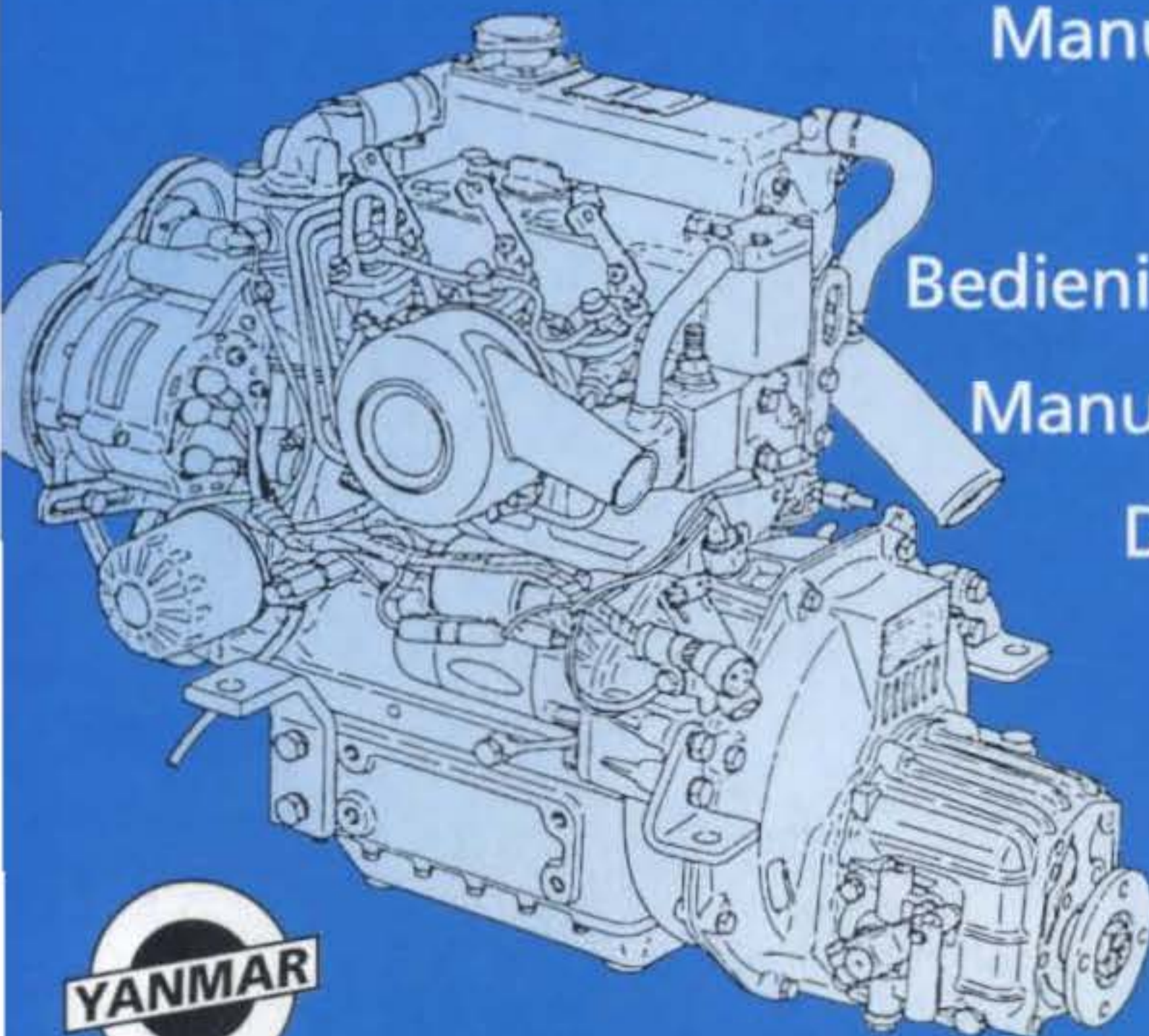

YANMAR DIESEL ENGINE